

CE



Torque Tool Tester (TTT) Series 2

OPERATOR'S HANDBOOK (PART No. 34295) Issue 3
(ENGLISH)

FOR USE WITH TTT'S FITTED WITH VERSION 37712.202 & 37712.203 SOFTWARE

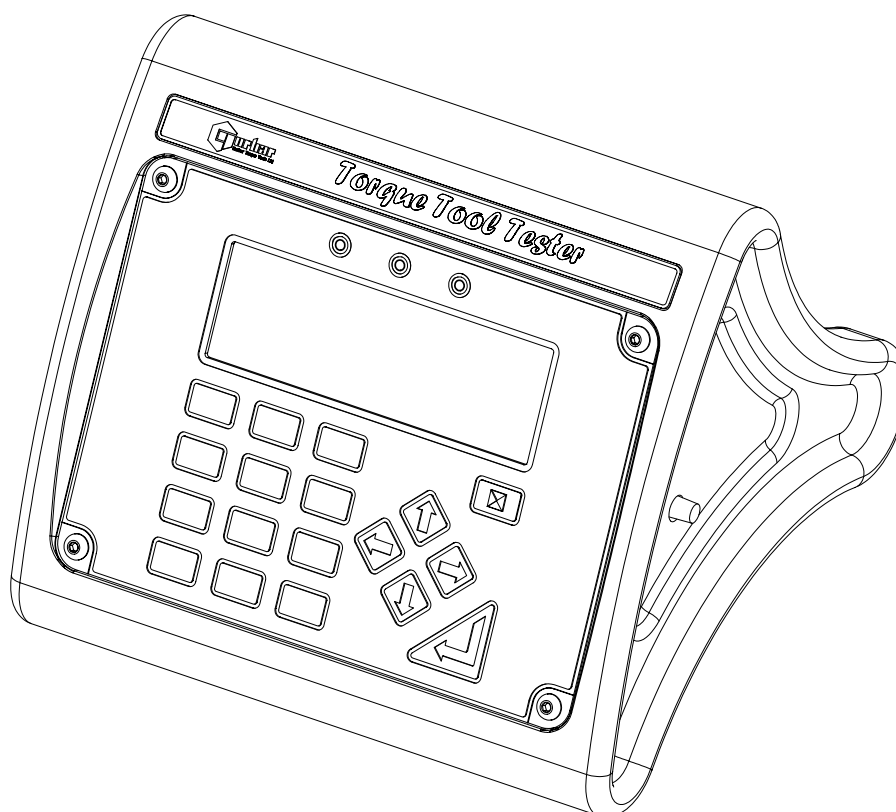

MODEL NUMBERS COVERED BY THIS MANUAL

43215 TTT

NORBAR TORQUE TOOLS LTD, Beaumont Road, Banbury, Oxfordshire, OX16 1XJ, UNITED KINGDOM
Tel : + 44 (0) 1295 270333, Fax : + 44 (0) 1295 753643

www.norbar.com

enquiry@norbar.com

CONTENTS

	<u>PAGE</u>
Introduction	2
Parts included	2
Accessories	2
Features and Functions	3
Set Up	4
Preparation	4
Using key pad	5
Configure for use	6
1. Limits	6
2. Current settings	7
3. Return to measure	7
Flow Diagrams	8
Measure	11
Screen Layout	12
Modes of measurement	14
Power saving & power down	15
Limits	16
External Transducer Interface	17
Ancillaries	19
Serial Port	21
Specifications	23
Maintenance	24
Trouble shooting	25
Glossary of terms	26

INTRODUCTION

Torque Tool Tester (TTT) is a bench top measuring instrument which has two external Transducer inputs. It has 6 measurement modes, 13 units of torque, 8 target limits and text displayed in 11 languages.

PARTS INCLUDED:- _____

Part Number	Description	Quantity
43215	Torque Tool Tester Instrument.	1
38877	ac power adapter.	1
	Power cord.	1
34295	Operators Handbook.	1
	Calibration Certificate.	1
34293	Quick reference card(s).	
39264	Serial data lead.	1
26716	TTT carry case.	1

ACCESSORIES:- _____

Part Number	Description
60216.200	TTT to 10 way lead, for Norbar Rotary Transducers
60217.200	TTT to 6 way lead, for Norbar Static & Annular Transducers
60248	Serial Data Lead Kit
Contact Norbar	Various torque transducers

FEATURES AND FUNCTIONS



- ▶ The pictorial panel allows easy mode selection for the 6 modes of operation.
- ▶ 2 transducer connectors.
- ▶ Automatically recognises any 'SMART' Norbar transducer.
Can also work with most mV/V transducers from Norbar or other manufacturers.
- ▶ 5 digit resolution for all Norbar transducers.
- ▶ Operational from internal rechargeable battery or ac supply.
- ▶ Fast battery charge in 3 hours 20 minutes.
- ▶ There are 8 sets of limits available.
Each limit has a target value and upper and lower allowances.
The display shows LO / OK / HI with bright LED's to signal AMBER / GREEN / RED for easy confirmation. The limit status is also output on the ancillaries connector.
- ▶ Pulse count feature in Impulse Tool mode & Clutch Tool mode.
- ▶ User selectable frequency response for each mode of operation.
- ▶ Password protection of all user selectable features. The instrument can be issued to users with only the required modes of operation and units of measurement enabled. This feature can virtually eliminate operator induced errors.
- ▶ Ancillaries connector with analogue output & GO/NO GO control for external equipment.
- ▶ Serial Port Connector for data output to computers and printers.
Options include sending time & date, limit status and continuous output.

SET UP

PREPARATION:-

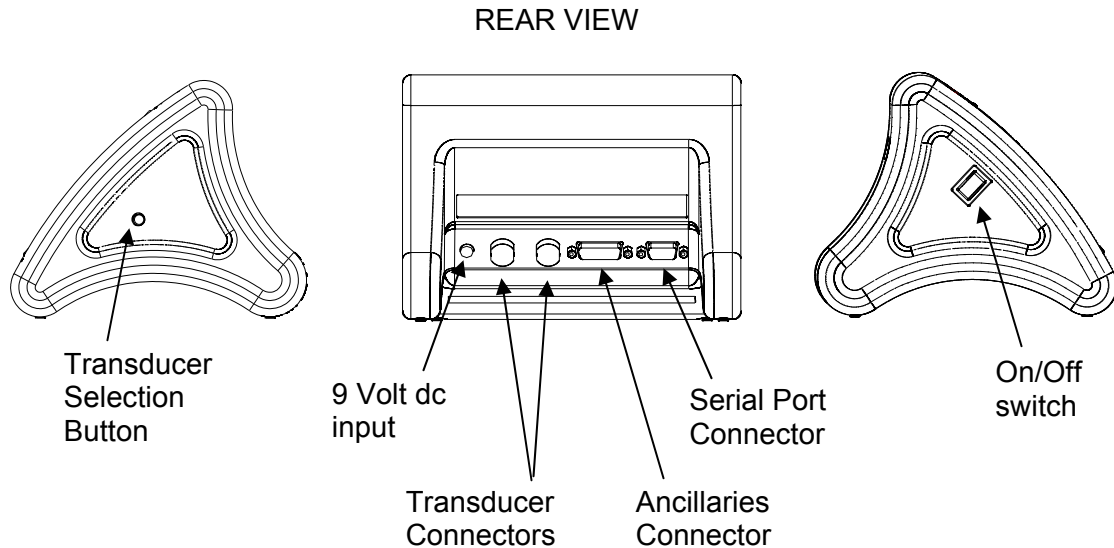
If the equipment is used in a manner not specified by the manufacturer, the protection provided by the equipment may be impaired.



1. Connect transducer(s) to be used, plug cable into transducer connector.
2. Ensure transducer selection switch is in the correct position for the transducer in use.
See  and  symbols next to transducer connectors.
3. To output data to an external device (PC or printer) connect to the SERIAL PORT
4. If using with a control or shut-off system, plug into ANCILLARIES connector.
5. The TTT can be powered from mains or battery. It is essential to charge the internal battery for 200 minutes (3 hours & 20 minutes) before battery use. To charge the internal battery connect the ac power adapter between the TTT (9 volt dc input) and a live ac supply.

TIP: Insert 9Vdc connector into TTT before applying ac mains to ensure correct charging.

TIP. If the power cord has no plug fitted, wire as follows:

BROWN-LIVE

BLUE-NEUTRAL

GREEN / YELLOW-EARTH

If in doubt consult a qualified electrician

TIPS: The display backlight is ON when connected to ac power.
The TTT can be used whilst the battery is charging.
Recharging is independent of the on/off switch.
The battery can be charged continuously.

WARNING! ALLOW THE TTT TO EQUALISE TO THE AMBIENT TEMPERATURE/HUMIDITY BEFORE SWITCHING ON. WIPE OFF ANY MOISTURE BEFORE USE.

USING THE KEY PAD:-_____





All TTT settings are accessed in menus that are set by the front panel keys.

The keys have the following functions:

For entry of alpha characters, Press and hold the key until character is displayed then release:

Numeric	1	2	3	4	5	6	7	8	9	0
Alpha	ABC	DEF	GHI	JKL	MNO	PQR	STU	VW	XYZ	

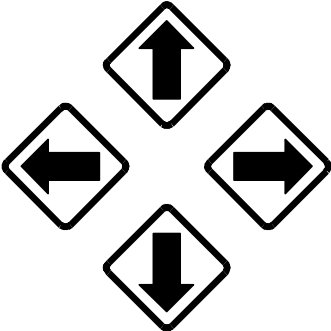
NOTE:- . The keys 0 – 9 are shortcuts for menu selection.

Key	Function
	Entry of: # % () * , / : = \ _
	Entry of: . (full stop or decimal point) + -
	<ul style="list-style-type: none"> a) To go through menu options and choices. b) Left arrow becomes delete when entering alphanumeric data. c) Right arrow becomes space when entering alphanumeric data. d) Use down arrow to move on to next option in a set up menu. e) Use left and right arrows for quick selection of torque units in measurement screen.
	Exit.
	Confirm change. <i>NOTE: If the change is not confirmed, it will not be made.</i>

TIP: When in a set up screen, after entering one option press the down arrow to enter the next. When all entry's have been made, press '↵'.

CONFIGURE FOR USE:- _____

Turn TTT on and wait for LOGO.

The TTT will either enter the measure screen or display 'CONNECT TRANSDUCER'.

Press



to obtain SET UP menu:

<p>17. SET UP</p> <p>SOFTWARE # 37712.XXX</p> <p>1. LIMITS</p> <p>2. CURRENT SETTINGS</p> <p>3. RETURN TO MEASURE</p>

NOTE: All set up settings are password protected, the default password is 000000.

TIP: If password is lost, contact Norbar quoting the coded number in brackets on the password menu

1. LIMITS

The user can set up to 8 target values that each have two settable LIMITS.

To set the limits the following is needed:

Parameter	Comment
Target Number	Select 1 to 8
Units for limits	Select torque units
Target value	Torque value required.
Upper limit	The % allowed above target
Lower limit	The % allowed below target
Operate	OFF or Clockwise or Anticlockwise or Both directions
Confirm limits	Limit values shown in % and torque units.

Select next target to set up. When finished press



For more information see flow diagram on page 8.

2. CURRENT SETTINGS

All settings are password protected (default password = 000000) except 'PRINT DEFAULTS'.

Setting	Options	Comment
LANGUAGE	ENGLISH, FRANCAIS, DEUTSCH, ITALIANO, ESPAÑOL, DANSK, NEDERLANDS, SUOMI, NORSK, SVENSKA, PORTUGUES.	Select from choice.
PASSWORD	Any 6 characters.	Default password = 000000
DATE & TIME	Set date DD/MM/YY or MM/DD/YY	24 hour clock with date.
MODE FREQUENCY	100Hz to 2500Hz.	Select mode then select frequency from list. OTHER FREQUENCY allows a custom value.
SERIAL PORT	See serial port section	Select required options.
FIRST PEAK SENSITIVITY	LOW / MEDIUM / HIGH	This is the amount by which the torque must drop to register a first peak. LOW must drop 10% of reading MEDIUM must drop 5% of reading HIGH must drop 2.5% of reading
AUTO RESET HOLD TIME	1 / 2 / 3 / 4 seconds	The time allowed for automatic reset in 'Click & Cam' mode.
TRIGGER FROM	0.5% to 99% of transducer capacity	This is the point the memory mode starts to work, all modes will 'TRACK' below this setting. This can help overcome false results. Values entered below 0.5% will act as 0.5%.
UNITS	All units	Turn off unwanted torque units.
MODES	All modes	Turn off unwanted modes.
POWER DOWN TIME	0 to 99 minutes	The time before power down starts. Set to '0' to disable.
PRINT DEFAULTS		All current settings and limit settings can be printed.

TIP: When ↑ or ↓ is shown on screen, this means more menu items are available.

For more information see flow diagram on page 10.

3. RETURN TO MEASURE

This option allows the user to view the measurement screen.

For 'SMART' transducers the measure is automatically seen.

For 'NON-SMART' transducers the option to store transducer details is available.

For more information see flow diagram on pages 8 & 9.

FLOW DIAGRAMS :-

All set up menus are numbered on the TTT for ease of identification.

Menu structure + limits flow diagram

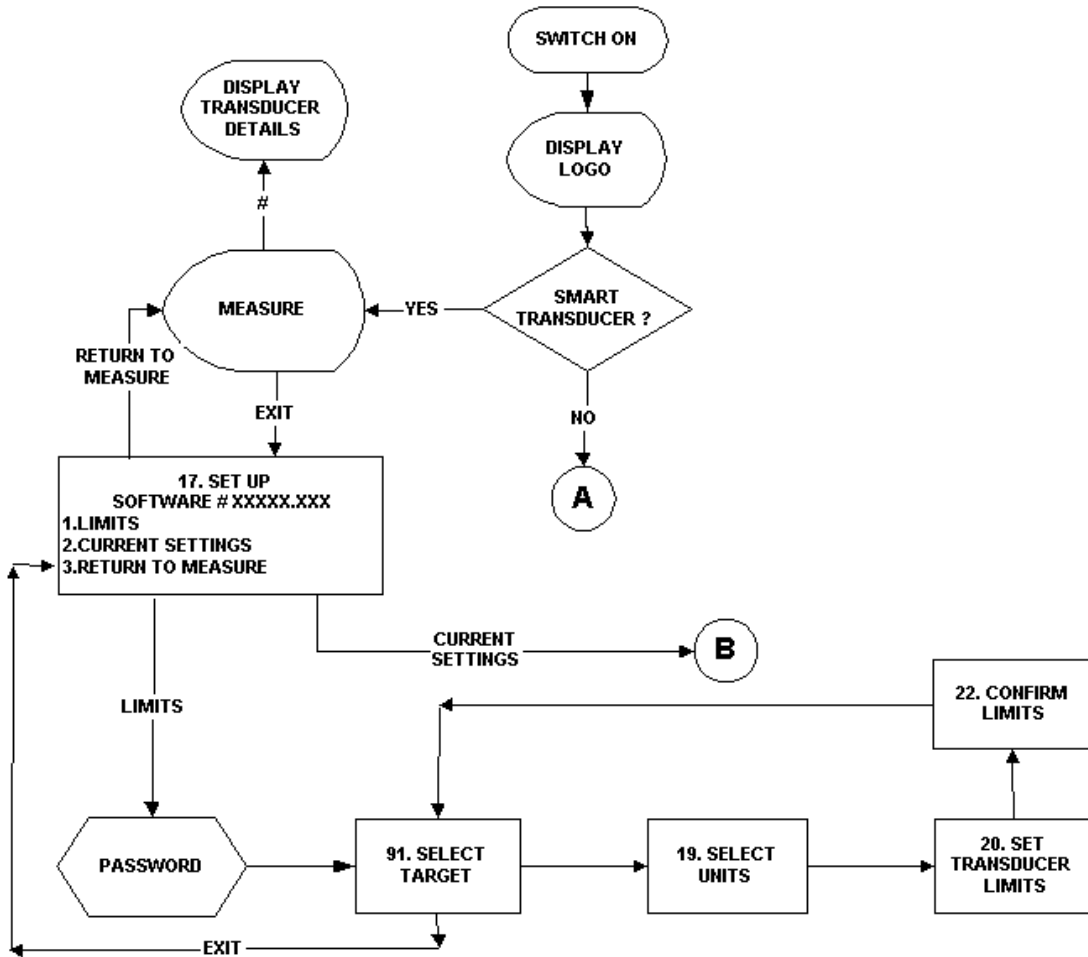

Password flow diagram

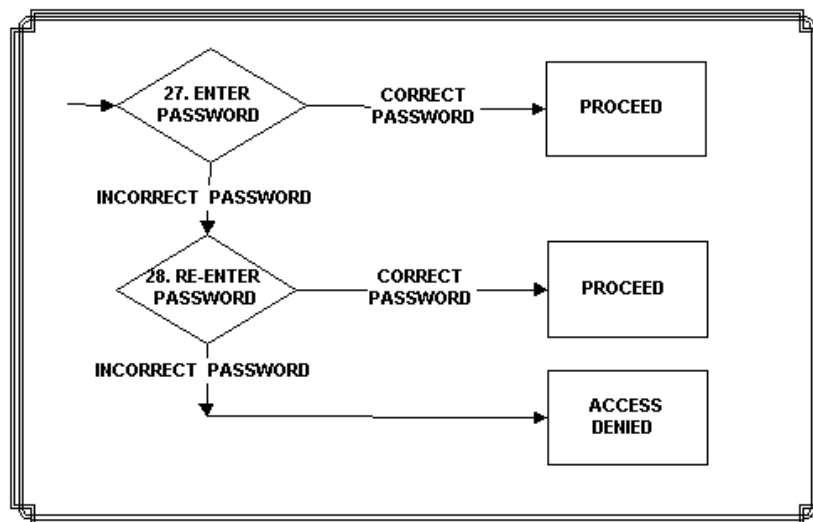

Measure flow diagram

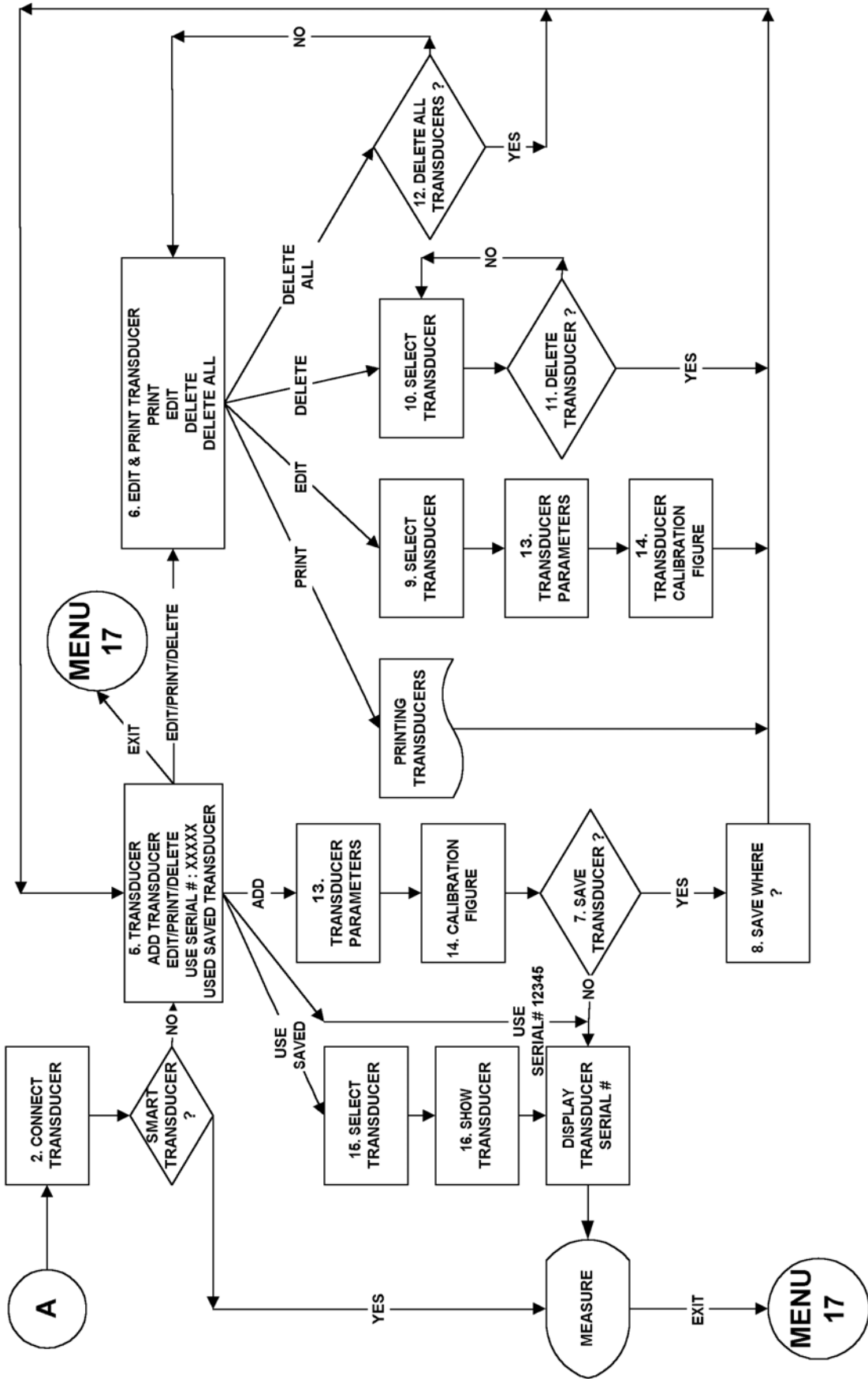

Current settings flow diagram

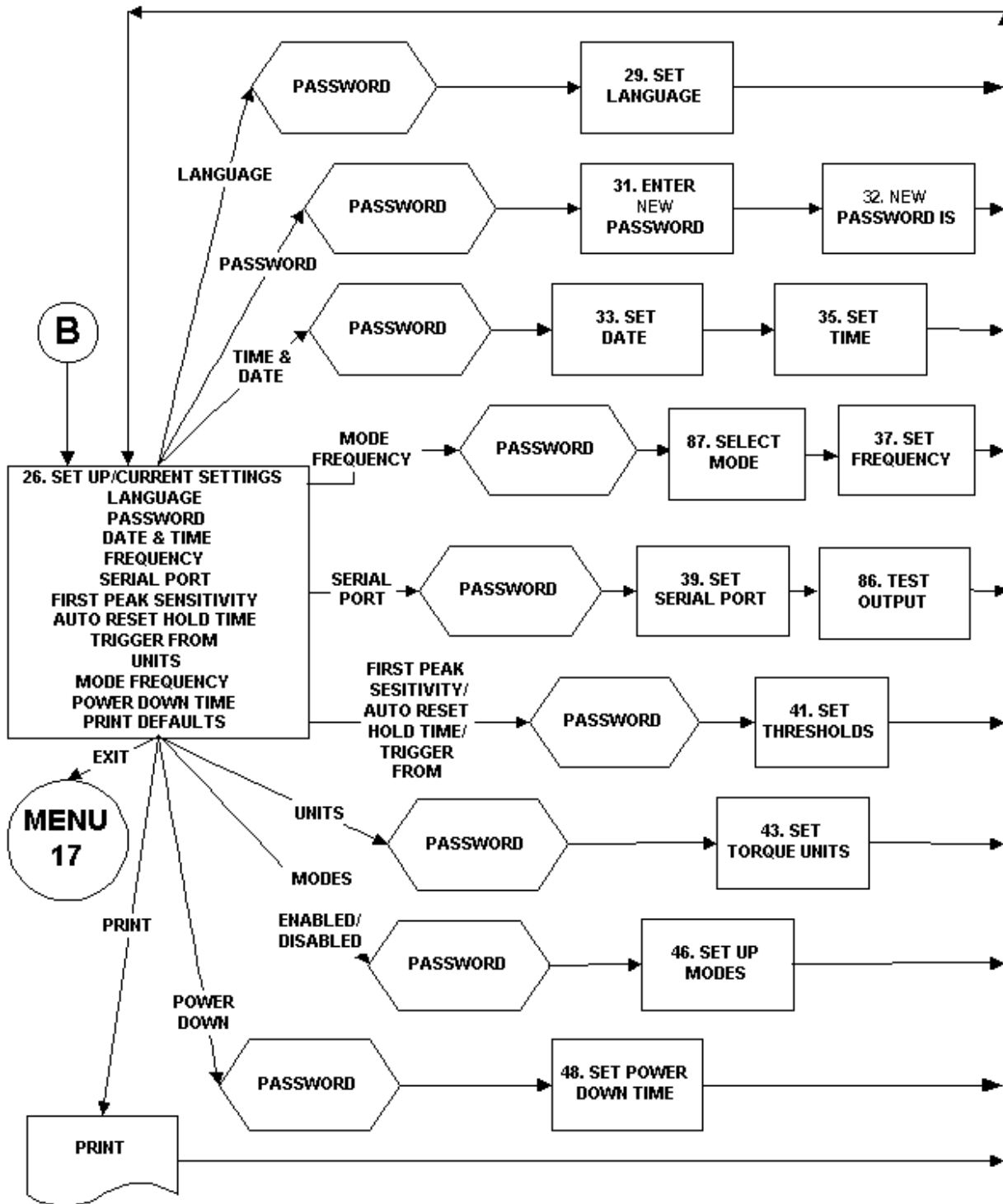

MEASURE

Set up the TTT as described in the previous section.

Turn TTT on.

For 'SMART' transducers the TTT automatically shows the transducer serial number then goes to measure.

TRANSDUCER SERIAL # XXXXX

Note: If the word 'LINEARISED' and direction arrows appear on this screen then the TTT is using a second order polynomial to linearise the transducer.

If 'Menu 2' is shown, then either:

- A. The 'SMART' transducer is not connected.
- B. The transducer is 'NON-SMART'.
For 'NON-SMART' transducers the transducer details can be saved in the TTT for future use. These saved transducers can be edited or deleted from the TTT and the saved transducers can be printed. The last transducer used will always be retained for quick selection.
Follow 'measure flow diagram' in set up section & refer to TRANSDUCER CONNECTOR section.
- C. The 'Transducer Selection Button' is in the wrong position.

The TRACK screen is now displayed.
Exercise transducer in direction of use.
Press 'ZERO' to zero displayed torque.

TIP. The torque display may not zero if outside +/-3% of transducer capacity. This may be due to transducer overstrain. Return defective transducer to Norbar.

Select measurement mode required.

TIP. If any measurement mode does not function correctly, ensure that the 'TRIGGER FROM' setting is not set too high.



To exit any measurement screen and go into SET UP, press

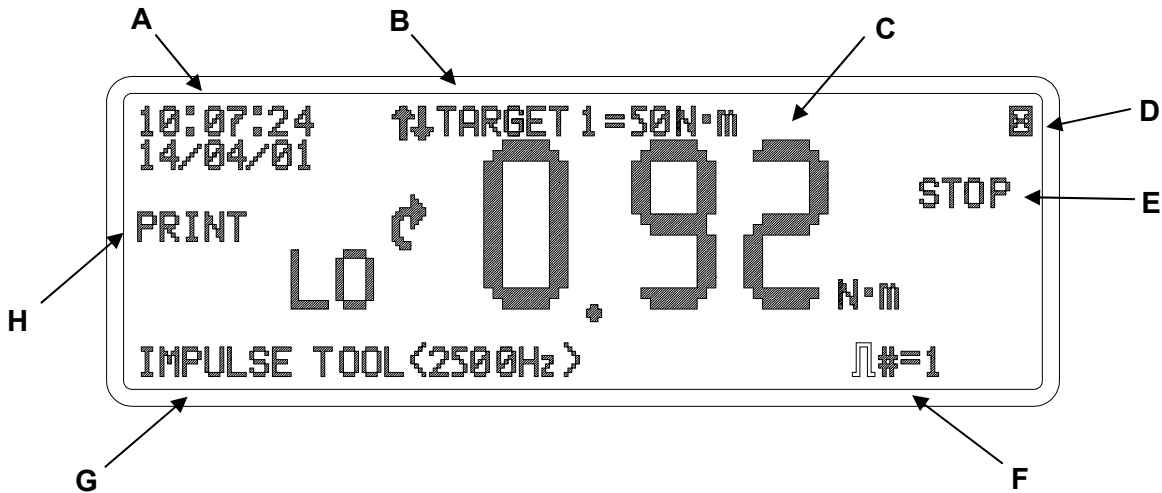

SCREEN LAYOUT :-



A. Time/Date display.

B. Press   to select target value and associated limits to be used.

C. Measurement display showing limit indication (if enabled), direction of measurement, torque reading and units of measurement.

D. Press  to exit.

It is recommended to exit from measure before changing the transducer.

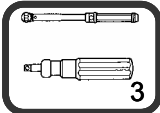





E. Indicates when to stop loading in  measuring mode.

F. Pulse count when in  or  measurement modes.

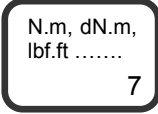
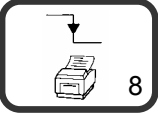
In Impulse tool & clutch tool a count is added every time the torque passes above & below the 'trigger from' setting. The trigger from is factory set to 5% of capacity.



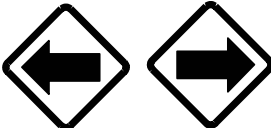

G. Current 'mode of measurement' in use along with frequency response set for that mode.

H. Press  to toggle between 'PRINT' and 'NO PRINT' on the display.

Key	Function
	Selection of enabled torque units.
	PRINT reading and RESET.
	PRINT/NO PRINT selection. PRINT enables serial output, NO PRINT disables serial output.
	To view transducer details in track mode. Shows: Serial #, Mode #, Units & Rated Capacity. Clockwise & anticlockwise mV/V Calibration figures. Clockwise & anticlockwise linearised values, where $T = a + bR + cR^2$ (T is torque & R is Ratio in mV/V).
	Zero transducer if in TRACK mode (It is recommended to check the zero when returning from power down). PRINT / RESET for measurement modes.
	For selection of torque units.
	PRINT reading and RESET.

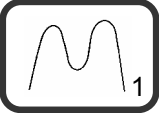
TIP. To simplify operation disable all units of measurement not required. See SET UP in CURRENT SETTINGS menu.

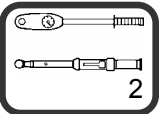
MODES OF MEASUREMENT :- _____

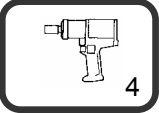
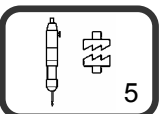
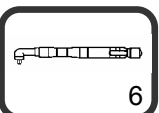
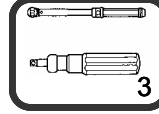
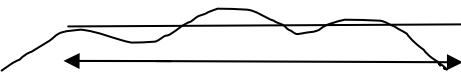
Mode	Mode (Filter setting)	How it works.	Visual representation
	TRACK (1000 Hz)	Follows signal.	
	Dial & Electronic (500 Hz)	Hold highest signal until reset by user.	
	Impulse Tool (2500 Hz)		
	Clutch Tool (2500 Hz)		
	Stall Tool (500 Hz)		
	Click & Cam (500 Hz)	Hold 1 st signal peak for set time, then resets.	

TIP. The frequency response for each mode can be independently set. See SET UP in CURRENT SETTINGS menu.

TIP. To simplify operation disable all modes of measurement that are not required. See SET UP in CURRENT SETTINGS menu.

TIP. For quick operation of Click & Cam mode, change AUTO RESET HOLD TIME to 1 SECOND in the CURRENT SETTINGS menu.

TIP. In Click & Cam mode the serial port will only output for a genuine first peak. Pressing enter or ZERO will not send an output.

TIP. If torque wrench readings are inconsistent in Click & Cam mode, change FIRST PEAK SENSITIVITY in the CURRENT SETTINGS menu. This will compensate for torque wrench sensitivity.

POWER SAVING & POWER DOWN :- _____

Battery life can be greatly increased from a minimum of 14 hours by making use of the power down function. When in Measure if no key is pressed or measurement reading taken in the specified time, the TTT will enter standby mode. The following is displayed:

SAVING POWER
PRESS ANY KEY TO CONTINUE

The following features should be noted:

The POWER DOWN TIME is set in the CURRENT SETTINGS.

For maximum battery life set POWER DOWN TIME to 1 minute.

To disable the power down feature set POWER DOWN TIME to 0 (zero).

The TTT does not enter power down when in a set up menu.

The analogue output will NOT work during power down.

TIP. Check the zero setting of the transducer on return from power down.

When the battery is low there is approximately 20 minutes of use left. The following is displayed:

WARNING #202
BATTERY LOW

When battery is flat the TTT must be turned off or recharged. The following is displayed:

WARNING #201
BATTERY FLAT
SWITCH OFF AND RECHARGE BATTERY

NOTE: From a very flat battery it may take 1 minute of mains power before the display will turn on.

LIMITS :- _____

In Measure the limits can be selected by pressing ↓ & ↑, the target is shown at the top of the screen. If no limits have been set 'LIMITS OFF' is shown. If limits are available '↓↑LIMITS OFF' is shown.

The limit status is shown in 4 ways:

1. On the display showing LO / OK / HI next to the torque value (updated at 2 Hz).
2. On YELLOW / GREEN / RED LED's on front panel (updated at 208 Hz).
3. On the Serial Port LO / OK / HI is sent before torque value (updated with serial port).
4. On the Ancillaries LO / OK / HI logic outputs (updated at 208 Hz).

TIP. The Ancillaries are updated quickly to give a fast response to an external control system.

NOTE: This difference in update rate may lead to very small differences between the changeover points. The most accurate value is that on the display.

The LED's & logic outputs change precisely with increasing torque, and at 0.5% of transducer capacity below the limit with decreasing torque. This eliminates the logic lines oscillating.

The status of the limits changes as follows:

Torque signal	Display	LED's	Serial port	Ancillaries
Zero band. (<0.5% of transducer capacity)	OFF	OFF	No output	No output
Under lower limit	LO	Yellow	LO	LO output
Within limits	OK	Green	OK	OK output
Above upper limit	HI	Red	HI	HI output

Limits: For operation in one direction only the opposite direction will be shown as LO.

The limit operation is dependent on the measurement mode:

Measurement mode	Limit operation
Track	Limits follow signal and are not held.
Dial & Electronic Impulse tool Clutch tool Stall tool	Limits status is held until RESET/PRINT is pressed.
Click & Cam	Limit status is held until after the auto reset timer has operated.

TIP. When TTT is switched on, the target shown is the last one used.

TIP. The TTT will automatically change torque units to those set by the limits.

EXTERNAL TRANSDUCER INTERFACE

INTRODUCTION :-

The 2 transducer connectors are designed for use with most four wire bridge strain gauge type transducers.

When used with Norbar 'SMART' transducers the calibration data will be automatically known.

For 'NON-SMART' transducers up to 20 sets of transducer parameters can be stored in the TTT for ease of use.

TIP Mark 'NON-SMART' transducers with their stored 'T' number for ease of identification.

Ensure transducer selection switch is in the correct position for the transducer in use.

See  and  symbols next to transducer connectors.

TIP. Press '#' in track mode to show details of 'SMART' transducer used.

TIP. If any of the transducer's parameters are changed i.e. re-calibration of mV/V value, the transducer's stored parameters must be edited prior to use. ('NON-SMART' only).

Norbar transducers with the following suffix are all suitable for use with the TTT:

XXXXX.IND	Transducer calibrated in mV/V.
XXXXX.INDA	Transducer calibrated in mV/V with integral angle encoder.
XXXXX.LOG	'SMART' transducer calibrated with a TTT in units of calibration. A mV/V figure is also supplied.
XXXXX.LOGA	'SMART' transducer with integral angle encoder calibrated with a TTT in units of calibration. A mV/V figure is also supplied.

NOTE:- Transducers supplied for use with the Pro-Log are compatible with the TTT.
The TTT will not display angle when interfaced to a .LOGA or .INDA transducer.

ETS Transducers supplied with an amplifier module will need to be modified for use with the TTT.

TRANSDUCER LEADS AVAILABLE:-

Part Number	Description
60216.200	TTT to 10 way Transducer connector
60217.200	TTT to 6 way Transducer connector
60223.200	TTT to no connector
60230.210	TTT to miniature Transducer connector

NOTE:- The suffix after the part number indicates the length of the lead in cm, thus XXXXX.200 = 2 metres. If Transducer leads are required of a non-standard length, the new suffix must be added to the part number when ordering (to the nearest metre).

SPECIFICATIONS :- _____

Parameter	Minimum	Maximum
Bridge Resistance (Ω)	350 Ω	1000 Ω
Millivolt / volt value (mV/V)	0.95 mV/V	3.15 mV/V
Zero balance	+/- 3% of transducer	+/- 9% of transducer capacity.
Torque Resolution	4.5 Active digits	5 Active digits.
Torque transducer capacity ranges	0.010000	1,500,000
Torque units	Dependent on transducer capacity and millivolt / volt value.	N.m, dN.m, cN.m, lbf.ft, lbf.in, ozf.in, ft.lb, in.lb, in.oz, kgf.m, kgf.cm, gf.m, gf.cm
Displayable overrange	120%	120%

PIN CONNECTIONS :- _____

Pin No	Function
1	+ve transducer excitation
2	-ve transducer excitation
3	+ve transducer signal
4	-ve transducer signal
5	Digital 0 volts
6	Digital +5 volts for transducer selected, digital 0 volts when not selected.
7	Rotary transducer angle input (Channel A)
8	Rotary transducer angle input (Channel B)
9	Serial clock (e ² prom)
10	Serial data (e ² prom)

CONNECTOR TYPE :- _____

Lemo® 10 way panel socket, size 2B. The mating part to this connector is a Lemo 10 way, size 2B free plug, manufacturers part number FGG.2B.310.CLAD722.

TIP. If the display shows 'SMART TD NOT INITIALISED' it is likely that:

- a) You have an unmodified ETS transducer plugged in.
- b) The transducer lead may have a broken connection.

Your 'SMART' transducer may have lost its stored data, return to Norbar.

ANCILLARIES

INTRODUCTION :-

The ancillaries connector contains GO / NO GO control limits for external equipment, an analogue signal output and a reset / print signal input.

PIN CONNECTIONS :-

Pin No	Function
1	Digital +5 volts (maximum current 5 mA)
2	External memory reset / print (Active High)
3	Low limit output (LO)
4	Pass limit output (OK)
5	High limit output (HI)
6	Not Used
7	Not Used
8	Auto reset display hold input (Active high)
9	Digital 0 volts
10	First Peak Detect (High output when first peak active)
11	Analogue Out
12	Analogue Out 2.5V
13	Analogue Out 0V reference (Do not connect to a noisy electrical ground)
14	Output of rotary transducer angle (Channel A)
15	Output of rotary transducer angle (Channel B)

TIP. The angle output is available for a Norbar Rotary Transducer. For use see Rotary Transducer handbook.

EXTERNAL MEMORY RESET / PRINT :-

Pins 1 & 2 are intended for use as an external RESET / PRINT:-

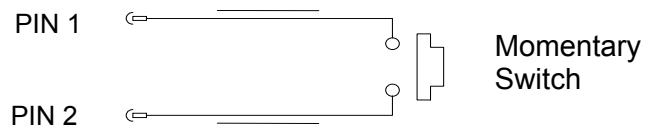

The switch must remain active for at least 200 mS.

LIMIT OUTPUTS :-

Pins 3, 4 & 5 are buffered logic outputs intended for Go/No Go control of external equipment.

All limit outputs are referenced to Pin 9 (Digital 0V). All limit outputs are active HIGH & change at 200 times per second. For more information on limits see 'LIMITS' menu which can be accessed via the 'SET UP' menu.

Limit output current, High = -0.8 mA, Low = 16 mA

ANALOGUE OUTPUT :- _____

The analogue output is designed for connection to a control system. It is a true analogue value, so has a very fast frequency response of above 10 kHz. The calibration of the analogue output is factory set and not adjustable, it is not affected by the instrument calibration.

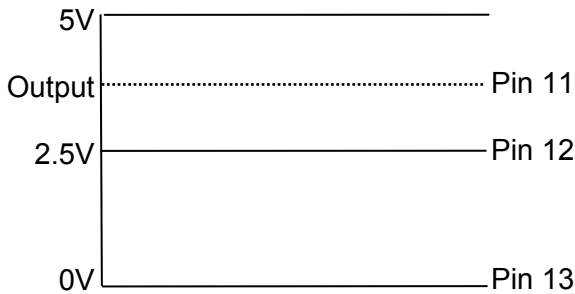

The output is PIN 11.

If the output is measured against PIN 12 (2.5V) the signal will swing positive for clockwise torque and negative for anticlockwise torque.

If the output is measured against PIN 13 (0V) the signal will always be positive, with zero torque around 2.5V.

TIP. Some transducers (Norbar Annular type) will give a negative output change for a positive torque. This is because they are designed to measure reaction torque.

The output voltage is a function of the mV/V value. The larger the mV/V value the larger the analogue output voltage. At transducer full scale the analogue output voltage (in volts) is numerically equal to the mV/V value divided by 2.

TIP. Find the mV/V value by pressing # in the track mode or from the transducer's certificate.

Using 2.5V (PIN12) as a reference:

Torque	Analogue output (PIN 11)		
	@ 1.0mV/V	@ 2.0 mV/V	@ 3.0 mV/V
- full scale of transducer	-0.5 V	-1.0 V	-1.5 V
Zero	0.0 V	0.0 V	0.0 V
+ full scale of transducer	+0.5 V	+1.0 V	+1.5 V

Using 0V (PIN13) as a reference:

Torque	Analogue output (PIN 11)		
	@ 1.0mV/V	@ 2.0 mV/V	@ 3.0 mV/V
- Full scale of transducer	2.0 V	1.5 V	1.0 V
Zero	2.5 V	2.5 V	2.5 V
+ Full scale of transducer	3.0 V	3.5 V	4.0 V

TIP. The analogue output will not operate in power down mode. If using the analogue output continuously then disable the power down feature by setting to 0 (zero).

The accuracy of the analogue output is +/- 2% of voltage reading. For a more accurate output value the voltage can be externally scaled against the displayed torque.

CONNECTOR TYPE :- _____

15 way female 'D' type connector.

SERIAL PORT

INTRODUCTION :-

The serial data is configured as DTE (Data Terminal Equipment) and conforms to RS-232-C specifications.

When the TTT is measuring, data can be output on the serial interface automatically when the click & cam mode timer operates or when the 'RESET / PRINT ' key is pressed. The information can include the measured value, units of measurement and time/date (as shown on the display). Output can also be requested externally via pin 2 (ancillaries connector), see ancillaries section.

SPECIFICATIONS :-

	Options	Factory Defaults	Comments
Parity	ODD, EVEN or OFF.	OFF	
Baud rate	1200, 2400, 4800, 9600 or 19200.	9600	The data rate.
Data bits	7 or 8.	8	
Stop bits	1 or 2.	2	
First character	+/- or NONE.	NONE	If required by receiver.
Output units	YES or NO.	YES	Torque units sent after data.
Output date & time	YES or NO	NO	Date & Time sent after data.
Output line feed	YES or NO	NO	Line feed sent after data.
Handshake	NONE, CTS or X-ON/OFF	NONE	If required by receiver.
Line delay	0.00 to 9999 SECONDS	0.50 SECONDS	Time delay in data output.
Continuous output	YES or NO	NO	Up to 11 readings per second in track mode.
	SET TO FACTORY DEFAULTS		

Maximum number of characters per line = 24.

Maximum number of requests in track mode = 1 every 3 seconds.

Transmitted data voltage levels are between +5 to +9 volts and -5 to -9 volts.

- TIP. If the serial port is not communicating with other equipment try:
- a) Check that control word on the TTT and the equipment receiving data match.
 - b) Check that the baud rate is set to the same as the equipment receiving data.
 - c) Check that the connecting lead is wired correctly at both ends.
 - d) Check if equipment receiving data requires the units of measurement inhibited or a leading character.
 - e) Select CONFIRM at the end of the serial port settings, the TTT will keep sending a 'TEST OUTPUT' message to help fault finding.

TIP. If the serial output is being overwritten set 'Output Line Feed' to YES.

TIP. If the Serial data is being sent too quickly the printer may not keep up, so data is lost. To slow down the TTT output change the 'Line delay' function.

HYPER TERMINAL :- _____

The standard Hyper Terminal® program found in Microsoft® Windows allows the user to view and store serial output data. For more information see www.norbar.com and select FAQ.

TIP. Downloading of data can be speeded up by changing the LINE DELAY to 0 SECONDS

TIP. To regulate the CONTINUOUS OUTPUT, set LINE DELAY to required time period.

LIMITS :- _____

The serial port will output LO / OK / HI when the limits are being used. Some software, including the Norbar 'Torque Wrench Calibration Software' (Part 37705.XXX), will not accept LO / OK / HI characters. To remove LO / OK / HI set FIRST CHARACTER to '+/-'.

The following table gives all options for the FIRST CHARACTER setting:

Setting:	Direction:	Example with No Limits	Example with Limits
+/-	Clockwise	+1.0335 N.m	+1.0335 N.m
	Anti Clockwise	-1.0335 N.m	-1.0335 N.m
NONE	Clockwise	1.0335 N.m	LO 1.0335 N.m
	Anti Clockwise	-1.0335 N.m	LO-1.0335 N.m

PIN CONNECTIONS :- _____

Pin No	Function
1	Not Connected
2	Received data (to TTT)
3	Transmitted data (from TTT)
4	Not Connected
5	Signal ground 0V.
6	Not Connected
7	Not Connected
8	CTS (clear to send)
9	Not Connected

DATA OUTPUT EXAMPLE :- _____

Code : DP=Decimal Point. CR=Carriage Return. SP=Space.
TTT with the serial port set to the factory defaults. Reading 1068.4 lbf.ft (clockwise).

1	0	6	8	DP	4	SP	l	b	f	DP	f	t	CR
---	---	---	---	----	---	----	---	---	---	----	---	---	----

CONNECTOR TYPE :- _____

9 way male 'D' type connector.

CONNECTING LEAD :- _____

A 9 way female to 9 way female null modem connecting cable is included with the Pro-Test for connection to PC's with a 9 way male connector. Alternatively use the Serial Data Lead Kit (part no 60248).

SPECIFICATIONS

Input voltage	Equivalent torque	Accuracy	Calibration uncertainty*
@0.5 mV	5% of full scale	±0.1% of reading	±0.13%
@1.0 mV	10% of full scale	±0.05% of reading	±0.08%
@2.0 to 18.9 mV	20% to 110% full scale	±0.05% of reading	±0.06%

*Using a coverage factor of k=2, to give a confidence level of approximately 95%.

Resolution	5 digits for all Norbar transducers.
Display	240 x 64 pixel dot matrix display. With update rate of twice per second (2Hz).
Zero suppression	TRACK None. ALL OTHER MODES Suppressed from 0 to approximately 0.5% of transducer calibration range.
Password	000000 (default), must be 6 characters.
Time/date	HH:MM:SS 24 Hour clock. DD/MM/YY or MM/DD/YY date format.
Time/date compliance	To year 2062.
Units of measurement	See EXTERNAL TRANSDUCER INTERFACE section.
First peak sensitivity	2.5%(High), 5%(Medium), or 10%(Low) of reading.
Auto reset hold time	1, 2, 3 or 4 seconds
Frequency response	8 th Order Butterworth low pass filter with a -3dB point settable from 100 to 2500 Hz
Trigger from setting	0 to 99% of transducer capacity.
Operating temperature range	+5°C to +40°C.
Storage temperature range	-20°C to +70°C.
Maximum operating humidity	85% Relative Humidity @30°C.
ac power adapter	90 to 264 Volts a.c. at 50-60 Hz input. 9V, 300 mA D.C. output (centre positive).
Power down time	1 to 99 minutes (enter 0 to disable)
Power consumption	2.4 W - maximum.
Power cable	2 metres (6 ft 6 ins) long minimum.
Power plug fuse (if fitted)	1 Amp
Battery pack	1500 mAh, 6.0 volt (5 cell) NiMH (Recharge time 200 minutes).
Back up battery	Renata 190 mAh (CR2032FH).
Weight	1 Kg (2.2 lb).
Dimensions	150mm high x 200 mm wide x 180 mm deep.
Case materials / finish	Rigid polyurethane with fine texture acrylic paint finish.
Environment	Indoor use within a light industrial environment.
Electromagnetic Compatibility (EMC) Directive	In conformance with EN 61326 : 1997
Low voltage directive	In conformance with EN 61010-1 : 2001. To environmental conditions Pollution Degree 2 & Installation Category (Over voltage Category) II.

Due to continuous improvement all specifications are subject to change without prior notice.

MAINTENANCE

TTT CALIBRATION :- _____

Your TTT has been supplied with a certificate of calibration. To maintain the specified accuracy it is recommended that the TTT is recalibrated at least once per year. Re-calibration should be carried out at Norbar or by a Norbar approved agent, where all the facilities to ensure the instrument is functioning at maximum accuracy are available.
Do not remove front panel or case; there are no calibration settings inside.

EXTERNAL TRANSDUCER CALIBRATION:- _____

To maintain the specified accuracy it is recommended that external transducers are recalibrated at least once per year. Re-calibration and repair should be carried out at Norbar or by a Norbar approved agent.

BATTERY REPLACEMENT :- _____

There are 2 batteries in the TTT.

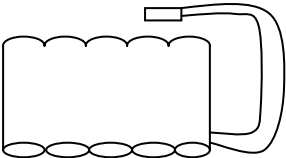
Description	Use	Reason for replacement	Battery markings	Norbar part #
Coin cell 3V 	Time & date	Time & date fail	CR2032	39202
Battery pack 6V NiMH 	Powers TTT	TTT has short battery life	38876	38876

To replace battery(s):

1. Turn TTT off.
2. Remove 4 front screws with 2.5mm HEX key.
3. Lift the top of the panel to show PCB.
4. Replace coin cell (marked BATT1 on PCB) or replace battery pack (marked CONN4 on PCB).
5. Fit panel without trapping wires and fit 4 screws.

Dispose of used battery in a safe way. Do not incinerate, mutilate or short circuit.

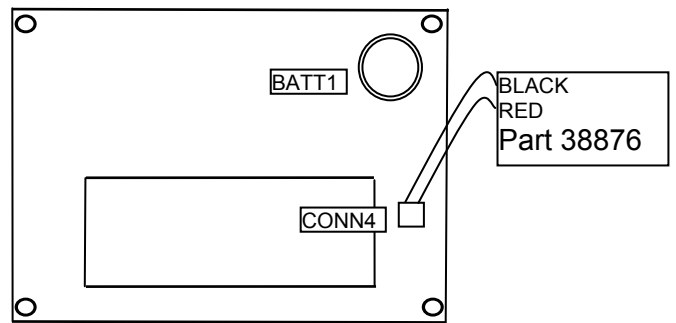

Inside TTT.

REPAIR :- _____

Repair should be carried out at Norbar or by a Norbar approved agent, where all the facilities to ensure the instrument is functioning at maximum accuracy are available.

Only remove front panel for battery replacement; there are no other parts for user repair inside.

CLEANING:- _____

Do not use abrasives or solvent based cleaners.

TROUBLE SHOOTING

Tips are located within the handbook to help with troubleshooting.

ERROR MESSAGES:- _____

Error messages are displayed to help the user, with audible warnings given when necessary. Common error messages are:

Error #	Message	Comment
312	TRANSDUCER CAPACITY > 1,500,000	Wrong value entered
313	TRANSDUCER CAPACITY < 0.01	Wrong value entered
314	CALIBRATION FIGURE NOT 0.95 TO 3.15 MV/V	Wrong value entered
316	NO TRANSDUCER TO EDIT / PRINT	No stored transducers
317	DELETE A SAVED TRANSDUCER FIRST	All 20 locations full.
318	SET + LIMIT TOO HIGH	Wrong value entered
319	SET - LIMIT TOO HIGH	Wrong value entered
320	INCORRECT TORQUE/LOAD/PRESSURE VALUE	Wrong target value entered
321	FREQUENCY NOT 100 Hz – 2500 Hz	Wrong value entered
322	POWER DOWN TIME 0-99 MINUTES	Wrong value entered
324	SMART TRANSDUCER NOT INITIALISED	Transducer's stored data is blank

PROBLEMS:- _____

Problem	Likely Solutions
No TTT display.	Check on/off switch is ON. Charge battery for 1 minute.
Battery will not charge.	Check display backlight, this is ON when charging. Check ac power adaptor is ON (green LED will glow). Check electrical power supply and fuse in plug (if fitted).
Displays Menu 82: 'CLOCK NOT INITIALISED'	The back up battery has failed. See Maintenance section or return to Norbar.

For more complex faults please contact Norbar distributor / manufacturer.

GLOSSARY OF TERMS

Word or Term	Meaning
ac	Alternating current.
Alphanumeric	The same key can enter letters and numbers.
Current Settings	The settings that are being used.
dc	Direct current.
ETS	Electronic Transducer System.
First peak sensitivity	The amount by which the reading must fall from a peak for the display to be held.
Frequency Response	Frequency value below which signals are passed.
Hold Time	The length of time a reading is displayed for until it is automatically reset.
Hz	Hertz, unit of frequency.
LED	Light Emitting Diode.
Lemo	Reference for manufacturers of connector.
mA	One thousandth of an amp (milli amp).
mAh	Rate of charge/discharge of a battery (milli ampere hour).
Millisecond (mS)	One thousandth of a second (0.001 second).
Millivolt (mV)	One thousandth of a volt (0.001 volt).
Millivolt per volt (mV/V)	Ratio of millivolt output to voltage input.
NiMH	Nickel metal Hydride.
NON-SMART	Standard mV/V transducer (NON-INTELLIGENT).
PC	Personal Computer.
PCB	Printed Circuit Board
Power Down Time	The length of time that the TTT has not been used before the instrument goes into standby mode.
Print / No print	Print can be switched off to stop all serial port output.
Pulse Count	Display of how many torque pulses have been applied to the TTT for the measured value.
SMART	Serial Memory Automatic Recognition Transducer.
SMART Transducer	A transducer that holds its own calibration data, (INTELLIGENT).
Trigger From	Value at which the instrument stops tracking and memorises the reading.
TTT	Torque Tool Tester
Zero suppression	Value of torque that has to be achieved for the TTT not to display zero.