

**PNEUTORQUE[®] REMOTE CONTROL
STANDARD SERIES
TORQUE TOOLS**



CONTENTS

Part Numbers Covered by This Manual	2
Safety	3
General Safety Rules	3
Projectile Hazards	3
Entanglement Hazards	3
Operating Hazards	3
Repetitive Motions Hazards	4
Accessory Hazards	4
Workplace Hazards	4
Dust and Fume Hazards	4
Noise Hazards	5
Vibration Hazards	5
Additional Safety Instructions for Pneumatic Power Tools	5
PneuTorque® Specific Safety Instructions	6
Markings on Tool	6
Introduction	7
Parts Included	7
Accessories	7
Features and Functions	8
Set up Instructions	9
Torque Reaction	9
Examples of Tool Control Systems	11
Input Ports	12
Exhaust Port	12
Setting Torque for Fastener Tightening	13
Setting Torque for Fastener Releasing	13
Operating Instructions	14
Tightening	14
Releasing	15
Maintenance	16
Reaction Plate	16
Air Lubrication	16
Gearbox	16
Silencer	16
Filter	16
Drive Square	17
Cleaning	17
Disposal	17
Specifications	18
General	18
Standard Series	18
Declaration of Incorporation	20
Trouble Shooting	21
Glossary of Terms	21

PART NUMBERS COVERED BY THIS MANUAL

This manual covers all PneuTorque® (PT) Remote Control Standard Series tools; including the following:

Model (Standard Series)	Part Number			Square	Maximum Torque
	Single Speed	Manual Two Speed	Automatic Two Speed		
PT 1	16031.X	16031.XMTS	16031.XAUT	¾"	680 N·m
PT 1	16011.X	16011.XMTS	16011.XAUT	1"	680 N·m
PT 1A	16098.X	16098.XMTS	16098.XAUT	¾"	1,200 N·m
PT 1A	16097.X	16097.XMTS	16097.XAUT	1"	1,200 N·m
PT 2	16013.X	16013.XMTS	16013.XAUT	1"	1,700 N·m
PT 5	16015.X	16015.XMTS	16015.XAUT	1"	3,400 N·m
PT 6	16017.X	16017.XMTS	16017.XAUT	1½"	3,400 N·m
PT 7	16066.X	16066.XMTS	16066.XAUT	1½"	6,000 N·m
PT 9	16072.X	16072.XMTS	16072.XAUT	1½"	9,500 N·m
PT 11	16046.X	16046.XMTS	-	2½"	20,000 N·m
PT 12	18086.X	18086.XMTS	-	2½"	34,000 N·m
PT 13	16052.X	16052.XMTS	-	2½"	47,000 N·m
PT 14	16045.X	16045.XMTS	-	3½"	100,000 N·m
PT 15	18089.X	18089.XMTS	-	Note A	150,000 N·m
PT 16	18090.X	18090.XMTS	-	Note A	200,000 N·m
PT 17	18088.X	18088.XMTS	-	Note A	250,000 N·m
PT 18	-	16054.XMTS	-	Note A	300,000 N·m

NOTE A: The output drive and reaction components must be engineered specifically for each customer application. Consult Norbar.

PneuTorque® Remote Control Standard Series tools are also supplied with a handle. These are given a part number without an 'X' suffix and are covered by the operator manual part number 34317.

SAFETY

IMPORTANT: THIS OPERATOR MANUAL SHOULD BE KEPT FOR FUTURE REFERENCE.

General Safety Rules:

- For multiple hazards, read and understand the safety instructions before installing, operating, repairing, maintaining, changing accessories on, or working near the assembly power tool for threaded fasteners. Failure to do so can result in serious bodily injury.
- Only qualified and trained operators should install, adjust or use the assembly power tool for threaded fasteners.
- Do not modify this assembly power tool for threaded fasteners. Modifications can reduce the effectiveness of safety measures and increase the risks to the operator.
- Do not discard the safety instructions; give them to the operator.
- Do not use the assembly power tool for threaded fasteners if it has been damaged.
- Tools shall be inspected periodically to verify that the ratings and markings required are legibly marked on the tool. The employer/user shall contact the manufacturer to obtain replacement marking labels when necessary.

Projectile Hazards:

- Failure of the workpiece, of accessories or even of the tool itself can generate high-velocity projectiles.
- Always wear impact-resistant eye protection during the operation of the assembly power tool for threaded fasteners. The grade of protection required should be assessed for each use.
- Ensure that the workpiece is securely fixed.

Entanglement Hazards:

- Entanglement hazards can result in choking, scalping and/or lacerations if loose clothing, personal jewellery, neckware, hair or gloves are not kept away from the tool and accessories.
- Inappropriate gloves can become entangled with the rotating drive, causing severed or broken fingers.
- Rotating drive sockets and drive extensions can easily entangle rubber-coated or metal-reinforced gloves.
- Do not wear loose-fitting gloves or gloves with cut or frayed fingers.
- Never hold the drive, socket or drive extension.
- Keep hands away from rotating drives.

Operating Hazards:

- The use of the tool can expose the operator's hands to hazards including crushing, impacts, cuts, abrasions and heat. Wear suitable gloves to protect hands.
- These tools require the use of a suitable reaction which presents a crushing hazard. Ensure the set up instructions in this manual are followed.
- Operators and maintenance personnel shall be physically able to handle the bulk, weight and power of the tool.
- Hold the tool correctly; be ready to counteract normal or sudden movements and have both hands available.

- Maintain a balanced body position and secure footing.
- Release the trigger in the case of an interruption of the energy supply.
- Use only lubricants recommended by the manufacturer.
- Do not use in confined spaces and beware of crushing hands between tool and workpiece.

Repetitive Motions Hazards:

- When using a power tool for threaded fasteners, the operator can experience discomfort in the hands, arms, shoulders, neck, or other parts of the body.
- While using an assembly power tool for threaded fasteners, the operator should adopt a comfortable posture whilst maintaining secure footing and avoiding awkward or off-balanced postures. The operator should change posture during extended tasks, which can help avoid discomfort and fatigue.
- If the operator experiences symptoms such as persistent or recurring discomfort, pain, throbbing, aching, tingling, numbness, burning sensations or stiffness, these warning signs should not be ignored. The operator should tell the employer and consult a qualified health professional.

Accessory Hazards:

- Disconnect the assembly power tool for threaded fasteners from the energy supply before changing the tool or accessory.
- Use only sizes and types of accessories and consumables that are recommended by the assembly power tool for threaded fasteners manufacturer; do not use other types or sizes of accessories and consumables.

Workplace Hazards:

- Slips, trips and falls are major causes of workplace injury. Be aware of slippery surfaces caused by the use of the tool and also of trip hazards caused by the air line or hydraulic hose.
- Proceed with care in unfamiliar surroundings. Hidden hazards, such as electricity or other utility lines, can exist.
- The assembly power tool for threaded fasteners is not intended for use in potentially explosive atmospheres and is not insulated against coming into contact with electrical power.
- Make sure there are no electrical cables, gas pipes, etc., that can cause a hazard if damaged by use of the tool.

Dust and Fume Hazards:

- Dust and fumes generated when using assembly power tools for threaded fasteners can cause ill health (for example, cancer, birth defects, asthma and/or dermatitis); risk assessment and implementation of appropriate controls for these hazards are essential.
- Risk assessment should include dust created by the use of the tool and the potential for disturbing existing dust.
- Direct the exhaust to minimize disturbance of dust in a dust-filled environment.
- Where dust or fumes are created, the priority shall be to control them at the point of emission.
- All integral features or accessories for the collection, extraction or suppression of airborne dust or fumes should be correctly used and maintained in accordance with the manufacturer's instructions.
- Use respiratory protection in accordance with employer's instructions and as required by occupational health and safety regulations.

Noise Hazards:

- Unprotected exposure to high noise levels can cause permanent, disabling, hearing loss and other problems, such as tinnitus (ringing, buzzing, whistling or humming in the ears). Therefore a risk assessment and implementation of appropriate controls for these hazards are essential.
- Appropriate controls to reduce the risk may include actions such as damping materials to prevent workpieces from “ringing”.
- Use hearing protection in accordance with employer's instructions and as required by occupational health and safety regulations.
- Operate and maintain the assembly power tool for threaded fasteners as recommended in the operator manual, to prevent an unnecessary increase in noise levels.
- If the assembly power tool for threaded fasteners has a silencer, always ensure it is in place and in good working order when the assembly power tool for threaded fasteners is operating.
- Select, maintain and replace the consumable/tool as recommended in the operator manual, to prevent an unnecessary increase in noise.

Vibration Hazards:

- Exposure to vibration can cause disabling damage to the nerves and blood supply of the hands and arms.
- Wear warm clothing when working in cold conditions and keep your hands warm and dry.
- If you experience numbness, tingling, pain or whitening of the skin in your fingers or hands, stop using the assembly power tool for threaded fasteners, tell your employer and consult a physician.
- Operate and maintain the assembly power tool for threaded fasteners as recommended in the operator manual, to prevent an unnecessary increase in vibration levels.
- Do not use worn or ill-fitting sockets or extensions, as this is likely to cause an increase in vibration.
- Select, maintain and replace the consumable/tool as recommended in the operator manual, to prevent an unnecessary increase in vibration levels.
- Support the weight of the tool in a stand, tensioner or balancer, if possible.
- Hold the tool with a light but safe grip, taking account of the required hand reaction forces, because the risk from vibration is generally greater when the grip force is higher.

Additional Safety Instructions for Pneumatic Power Tools:



- Air under pressure can cause severe injury:
 - Always shut off air supply, drain hose of air pressure and disconnect tool from air supply when not in use, before changing accessories or when making repairs;
 - Never direct air at yourself or anyone else.
- Whipping hoses can cause severe injury. Always check for damaged or loose hoses and fittings.
- Cold air shall be directed away from the hands.
- Air lines with safe disconnect couplings, as supplied, are recommended. Whenever universal twist couplings (claw couplings) are used, lock pins shall be installed and whipcheck safety cables shall be used to safeguard against possible hose-to-tool and hose-to-hose connection failure.
- Do not exceed the maximum air pressure stated on the tool.

- For torque control and continuous rotation tools, the air pressure has a safety critical effect on performance. Therefore, requirements for length and diameter of the hose shall be specified.
- Never carry an air tool by the hose.

PneuTorque® Specific Safety Instructions:

- This tool is intended for use with threaded fasteners. Other uses within the limits of the tool may be appropriate. Please contact Norbar for guidance.
- The user (or the user's employer) shall assess the specific risks that can be present as a result of each use. This Operator Manual contains sufficient information for the end user to be able to perform an initial risk assessment.
- Unexpected direction of drive square movement can cause a hazardous situation.
- Isolate the tool from all energy sources before changing or adjusting the drive square or socket.

Markings on Tool

Pictograms on Tool	Meaning
	<p>Read and understand the Operator Manual.</p>
	<p>If a Reaction is purchased from Norbar it will include this label:</p> <p>Unexpected tool movement due to reaction forces or breakage of drive square or reaction bar may cause injuries. There is a risk of crushing between the reaction bar and workpiece. Keep hands away from reaction bar. Keep hands away from tool output.</p>

INTRODUCTION

The PneuTorque® Standard Series tools are non-impacting, air driven power tools designed for applying torque to threaded fasteners. Remote control versions have no direction/shut-off control on the tool but rely on external pneumatic circuitry (not provided) to provide this function. This opens up numerous application possibilities for the PneuTorque® ranging from simple stall shut-off in a hazardous working environment to sophisticated, multi-spindle torque and angle shut-off systems.

Together with the external pneumatic circuitry an external pressure regulator (Lubro Control Unit) is needed; this allows the air pressure to be adjusted to determine the stall torque from the graph provided. There are models to cover torque capacities of 680 N·m to 300,000 N·m.

The PneuTorque® must always be operated with the following:

- Filtered dry air supply. Minimum recommended compressor rating: 6.9 bar (100 psi), 19 l/s (40 CFM).
- Lubro Control Unit or similar Filter, Regulator and Lubricator Unit ½” Bore (12 mm).
- Impact or high-quality sockets.

Parts Included

Model	Part Number					
	Reaction Plate / Arm	Reaction Foot	Lifting Ring	Lubro Control Unit	Torque Wrench	Transporting Trolley
PT 1 & PT 2	16420	-	-	-	-	-
PT 5 & PT 6	16544	-	-	-	-	-
PT 7	16263	16344	-	-	-	-
PT 9	16387	16394	-	-	-	-
PT 11	16322	-	16348	16074	-	-
PT 12	18994	-	19262	16074	-	-
PT 13	16330	-	16311	16074	13049	16326
PT 14	16308	-	16311	16074	13049	16326
PT 15	Note A	-	-	16074	-	-
PT 16	Note A	-	16311	16074	13050	-
PT 17	Note A	-	16311	16074	13050	-
PT 18	Note A	-	16311	16074	13050	-

All tools include Operator Manual (Part number 34318), Calibration Certificate & Air pressure graph (Part number 34208)

NOTE A: The output drive and reaction components must be engineered specifically for each customer application. Consult Norbar.

Accessories

Part	Part Number
Replacement drive square	See Maintenance
Air Filter	18280
Silencer	16457
Lubro Control Unit	16074
Telescopic nose assembly (85.5 mm to 120.5 mm) for PT1 & PT2 only	16495
Transducers	Consult Norbar

FEATURES AND FUNCTIONS

Replaceable Drive Square

To avoid internal damage (especially due to torque overload), the output drive square has been designed to shear first. Tools are fitted with a drive square that can easily be replaced, alternative drive sizes are also available.

Clockwise / Counter-clockwise Control

Capable of tightening and releasing threaded fasteners.

Automatic Two Speed (AUT)

The automatic two speed gearbox option can reduce the fastener run down time. The initial run down is at 5 times normal operating speed before it automatically changes gear to apply the final torque.

Manual Two Speed (MTS)

The manual two speed gearbox option allows manual selection of 'slow' or 'fast' speeds, fast speed can reduce the fastener run down time. The difference in gearbox ratios between slow and fast speeds is approximately a factor of 5.

Optional Transducers

Electronic torque transducers can be directly fitted for precise torque monitoring, giving repeatability of up to +/- 2%.

Optional Angle Encoder

It is possible to fit an angle encoder to the PT. This measures the 6 air motor vanes and gives an output calculated by the following formula:

$$\text{Angle (degrees)} = \frac{6 \times \text{Velocity Ratio}}{360}$$

SET UP INSTRUCTIONS

Torque Reaction

The reaction arm is used to take the torque reaction force (which is equal and opposite to the tool output) and can also be used to mount the tool. The remote control tools are supplied with a reaction arm as standard (see Figure 1, 2, & 3). For other types of reaction arm see Accessories.

Position the tool in the reaction arm and fix in place as detailed below.

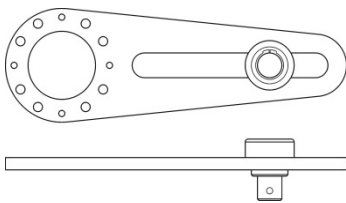

FIGURE 1 – Typical reaction (with sliding reaction square) for PT 1 to PT 5

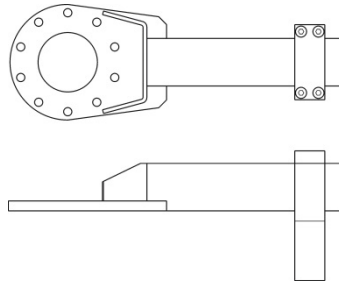

FIGURE 2 – Typical reaction (with adjustable foot) for PT 7 and PT 9

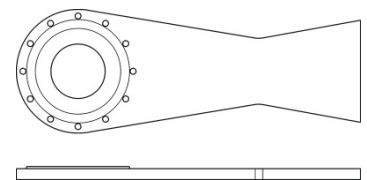

FIGURE 3 – Typical reaction for PT 11

Fit the reaction plate to the tool using the bolts provided.

Torque the bolts to the value specified on reaction arm, if no torque is specified use the following table:

Model	Reaction Plate / Arm	Fixing Bolt Size	Fixing Bolt Torque
PT 1 & PT 2	16420	2BA	9 N·m
PT 5 & PT 6	16544	¼" BSF	19 N·m
PT 7	16263	M10	83 N·m
PT 9	16387	⅜" BSF	75 N·m
PT 11	16322	M10	83 N·m
PT 12	18994	M12	150 N·m
PT 13	16330	M16	310 N·m
PT 14	16308	M16	310 N·m
PT 15	-	-	-
PT 16	-	M20	400 N·m
PT 17	-	M20	400 N·m
PT 18	-	M20	400 N·m

NOTE: It is recommended to check the reaction plate bolts are correctly tightened every week.

Securely mount the reaction arm.

TIP: Take the reaction as far away from the multiplier as practical.



WARNING: IF THE REACTION PLATE IS EXTENDED FORWARD OF THE DRIVE SQUARE, LARGER INDUCED BENDING STRESS WILL RESULT, SO THE PLATE MAY NO LONGER BE STRONG ENOUGH.

It is essential the reaction plate rests squarely against a solid object or surface adjacent to the fastener to be tightened. The contact area must be within the shaded area of Figure 4, with the contact area as large as possible.

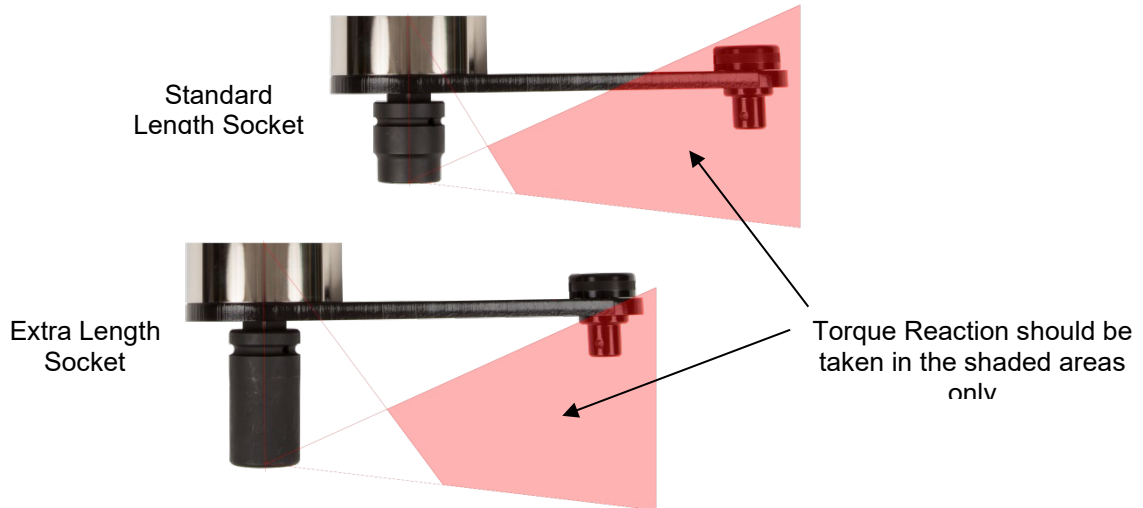

FIGURE 4 – Reaction limitations



WARNING: CARE MUST BE TAKEN TO ENSURE THAT THE REACTION ARM IS ONLY USED WITHIN THE LIMITATIONS SHOWN IN FIGURE 4.

For special applications or where extra deep sockets must be used the standard arm may be extended but only within the limitations shown on Figure 4. Alternative reaction devices are available.



WARNING: FAILURE TO OBSERVE THE LIMITATIONS SHOWN IN FIGURE 4 WHEN MODIFYING STANDARD REACTION ARMS MAY RESULT IN PREMATURE WEAR OR DAMAGE TO THE TOOL.

Standard drive square extensions **MUST NOT** be used as these will cause serious damage to the tool output drive. A range of nose extensions is available for applications where access is restricted. These are designed to support the final drive correctly.

When the PneuTorque® is in operation the reaction arm rotates in the opposite direction to the output drive square. The reaction arm must be allowed to rest squarely against a solid object or surface adjacent to the bolt to be tightened. (See Figure 5 & 6).



WARNING: ALWAYS KEEP HANDS CLEAR OF THE REACTION ARM WHEN THE TOOL IS IN USE OR SERIOUS INJURY MAY RESULT.



FIGURE 5 – Clockwise (FWD) reaction



FIGURE 6 – Counter-clockwise (REV) reaction

TIP: To extend tool life ensure the reaction point remains square to the multiplier; this will minimise stress on the output square. If the multiplier tilts under load, the reaction may not remain square.

TIP: To help socket location with PT 1 & PT 2 tools in remote or multi-spindle applications use a Telescopic Nose Assembly, Part number 16495.

Examples of Tool Control Systems

The remote control air motor requires a separate external pneumatic tool control system (not supplied as standard) for on / off and clockwise / counter-clockwise control of the tool. The direction of tool rotation is determined by pressurising either the clockwise (FWD) or counter-clockwise (REV) air inlet ports.

A Lubro Control Unit (Part Number 16074 – supplied where specified) is required to lubricate the air and control the air pressure so the correct torque is applied. Check the oil level in the Lubro Control Unit and fill to the correct level. (See MAINTENANCE section).

Ensure air hoses are clean and free from dirt before connecting. The air supply hoses and control valves must be $\frac{1}{2}$ " bore (12mm) and the hose from the supply to the control system must not be longer than 5 metres or the tools performance will be impaired. If the supply hose must be longer than 5 metres then $\frac{3}{4}$ " bore must be used.

Examples of tool control systems are shown in Figure 7 and Figure 8.

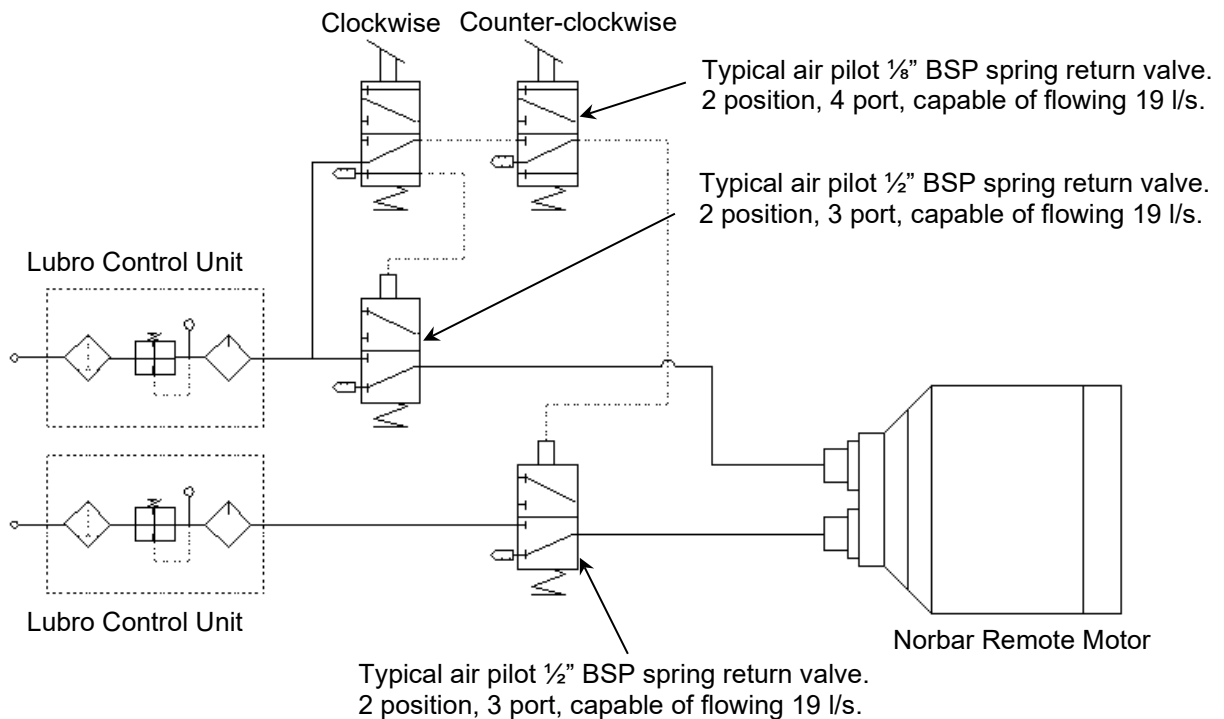

FIGURE 7 – Example of tool control system

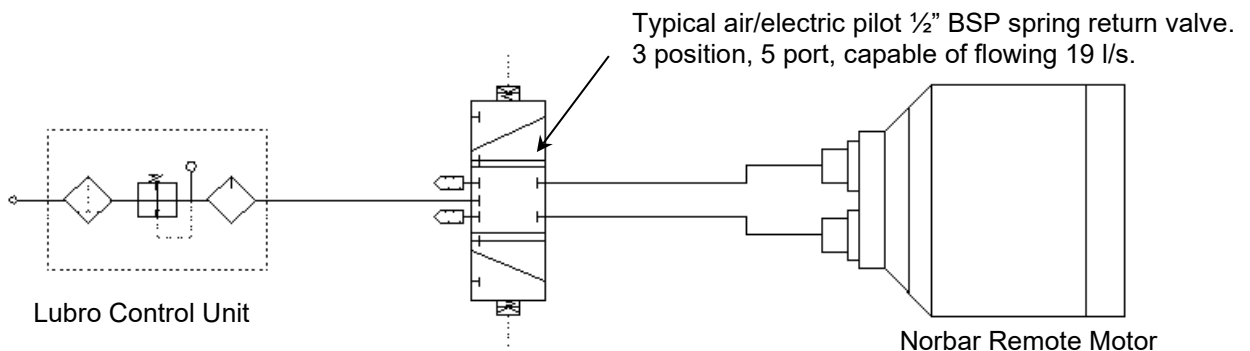

FIGURE 8 – Example of tool control system



WARNING: TO AVOID HAZARD FROM WHIPPING AIR HOSES MAKE ALL CONNECTIONS TO THE TOOL BEFORE TURNING ON THE AIR SUPPLY.

Input Ports

The input ports are located at the rear of the tool and covered by plastic protection caps (# 16199). Connect the air supply to the clockwise (FWD) and counter-clockwise (REV) ½" BSP connectors as shown in Figure 9.

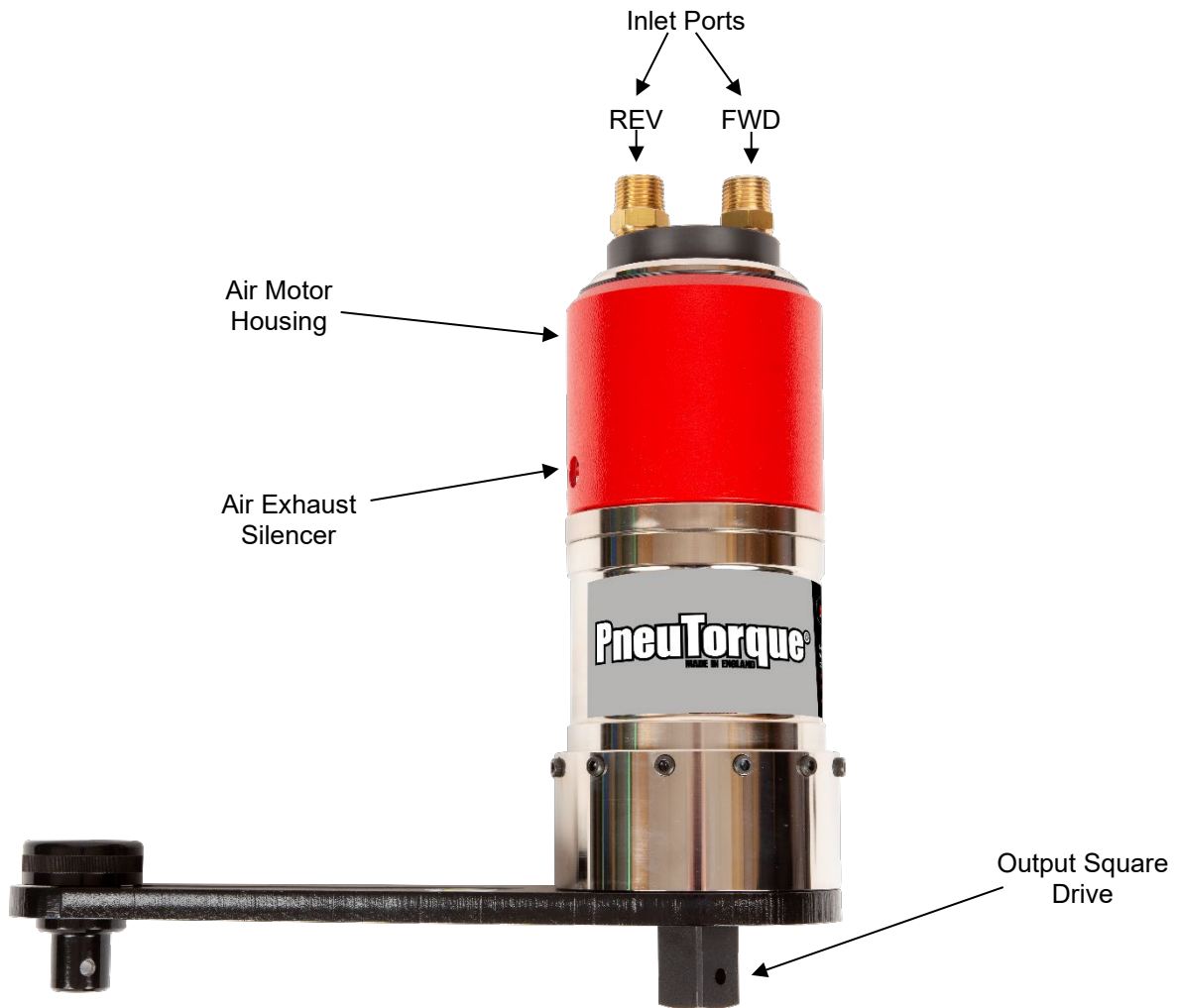

FIGURE 9 – Tool features

Exhaust Port

The exhaust port, located on the side of the tool, is common to both inlet ports.

TIP: As with any pneumatic tool a fine oil mist is present in the exhaust air. Please ensure the exhaust air cannot cause a hazard.

Setting Torque for Fastener Tightening

The tool stall torque is determined by the air pressure set on an external Lubro Control Unit (Part Number 16074 - supplied where specified).

Tools are supplied with an Air Pressure Graph which relates the torque output to the air inlet pressure. Set the torque output as follows:

1. Ensure the tool control system is set for the required rotation.
2. For Manual two speed tools (Part number *****.XMTS) select 'SLOW' speed.
3. Establish the air pressure required using the Air Pressure Graph.
4. Ensure the drive square is able to free run.
5. With the tool running, adjust the air pressure regulator until the correct pressure is shown on the air pressure gauge.

IMPORTANT: THE TOOL MUST BE FREE RUNNING WHILE ADJUSTING THE AIR PRESSURE TO GIVE THE CORRECT SETTING.

WHILE THE TOOL IS FREE RUNNING CHECK THAT LUBRO CONTROL UNIT IS SUPPLYING APPROXIMATELY SIX DROPS OF OIL PER MINUTE.

Setting Torque for Fastener Releasing

1. Ensure that the tool control system is set for the required rotation.
2. Establish maximum air pressure from the associated Air Pressure Graph or tool label.
3. Adjust the pressure regulator until the correct pressure is achieved.



WARNING: EXCEEDING THE MAXIMUM AIR PRESSURE WILL CAUSE OVERLOADING AND MAY LEAD TO SERIOUS DAMAGE.



WARNING: CHANGING THE AIR PRESSURE AFTER SETTING THE PRESSURE REGULATOR WILL CHANGE THE STALL TORQUE VALUE.

OPERATING INSTRUCTIONS



WARNING: KEEP HANDS CLEAR OF THE REACTION ARM.



WARNING: WHEN USING THIS TOOL IT MUST BE SUPPORTED AT ALL TIMES IN ORDER TO PREVENT UNEXPECTED RELEASE IN THE EVENT OF FASTENER OR COMPONENT FAILURE.



WARNING: CHANGING THE MAINS AIR PRESSURE AFTER SETTING THE PRESSURE REGULATOR WILL CHANGE THE STALL TORQUE VALUE.



WARNING: BEFORE USING TOOL, WEAR SUITABLE PPE, INCLUDING SAFETY SHOES, EYE PROTECTION, GLOVES AND OVERALLS.



WARNING: IF EQUIPMENT IS USED IN A MANNER NOT SPECIFIED BY THE MANUFACTURER, INJURY OR DAMAGE COULD RESULT.

Tightening

1. Fit PneuTorque® with the correct size impact or high-quality socket.
2. Ensure the external tool control system is correctly set.
3. Fit the tool onto the fastener. Locate reaction arm adjacent to the reaction point.
4. Complete the following instructions for SINGLE SPEED, AUTOMATIC TWO SPEED or MANUAL TWO SPEED tools:



Single Speed (Part Number with 'X' suffix)

5. Start the tool and allow it to continuously tighten the fastener. Full torque will only be applied when the motor stalls.
6. Stop tool and remove from fastener.

Manual Two Speed (Part Number “*****.XMTS”)

NOTE: ‘FAST’ speed is for initially running up of the fastener and ‘SLOW’ speed for applying the final torque.

5. Set speed selector to ‘FAST’.

TIP: To change the speed (see Figure 10):

- A. Ensure tool is not running.
- B. Pull selection knob out.
- C. Move knob to required speed setting.
- D. Ensure selection knob is fully engaged in recess.

6. Start the tool and allow it to continuously tighten the fastener.
7. When the tool motor stalls, stop the tool.



FIGURE 10 – ‘FAST’ speed above, ‘SLOW’ speed below.



NOTE: The final torque has NOT been applied yet.

8. Set speed selector to 'SLOW'.
9. Start the tool and allow it to continuously tighten the fastener. Full torque will only be applied when the motor stalls.

NOTE: The air pressure calibration graph is only correct in the 'SLOW' setting.

10. Stop tool and remove from fastener.

TIP: Where there are several fasteners in the joint, eg. a flange, it may be desirable to tighten all of the fasteners with the tool in 'FAST' gear. Then set the gear selector to 'SLOW' and apply final torque.

Automatic Two Speed (Part Number "*****.XAUT")

NOTE: These tools operate at a 'FAST' speed (approximately 5 times faster than normal) until torque is detected, then the tool automatically changes to 'SLOW' speed for the final tightening of the fastener.

5. Start the tool and allow it to continuously tighten the fastener. Full torque will only be applied when the motor stalls.
6. Stop tool and remove from fastener.

TIP: If the tool will not release from the bolt, run tool in the opposite direction for a fraction of a second.

NOTE: If the air pressure is released before the tool stalls, full torque will NOT be applied to the fastener.

TIP: If additional angle tightening is required, the air pressure may be increased. Do not exceed the maximum air pressure for the tool. Ensure the air pressure is reset to the required value for future torque tightening.

Releasing

1. Fit PneuTorque® with the correct size impact or high-quality socket.
2. Ensure external tool control system is correctly set.
3. Fit the tool onto the fastener. Locate reaction arm adjacent to the reaction point.
4. Start the tool to release the fastener.

TIP: If unable to release the fastener increase the air pressure to the tool. Do not exceed the maximum air pressure for the tool.



WARNING: EXCEEDING THE MAXIMUM AIR PRESSURE WILL CAUSE OVERLOADING AND MAY LEAD TO SERIOUS DAMAGE.

5. Remove tool from fastener.



WARNING: CHANGING THE AIR PRESSURE AFTER SETTING THE PRESSURE REGULATOR WILL CHANGE THE STALL TORQUE VALUE.

MAINTENANCE

To maintain optimum performance and safety, regular maintenance needs to be carried out. This section details the user maintenance required; other maintenance or repairs should be carried out by Norbar or a Norbar approved agent and should form part of a service. Service intervals will depend on the type of usage of the tools and the environment in which they are being used. The maximum recommended maintenance and recalibration interval is 12 months.

TIP: Steps the operator can take to reduce the amount of maintenance required include:

1. Use the tool in a clean environment.
2. Use an air compressor fitted with a dryer.
3. Ensure the Lubro Control Unit has sufficient hydraulic oil.
4. Ensure the Lubro Control Unit delivers hydraulic oil at the correct rate.
5. Ensure the Lubro Control Unit is regularly maintained, see product manual.
6. Maintain the correct torque reaction.

Reaction Plate

Every week check that the bolts fastening the reaction plate are tightened to the torque stamped onto the reaction plate.

Air Lubrication

Add Fuchs Silkair VG22 or Shell Tellus S2 VX15 or equivalent good quality hydraulic oil to the Lubro control unit.

Gearbox

Under normal operating conditions it is not necessary to re-grease the gearbox. The gearbox contains Shell Gadus S2 V220 or equivalent good quality grease.

Silencer

The silencer (#19188) should be changed every 12 months. This may be more frequent for high tool usage or dirty environments.

To change silencer:

1. Remove circlip from end of sleeve.
2. Slide sleeve to access silencer.
3. Change silencer.
4. Refit sleeve and circlip.



FIGURE 11 – Silencer location

Filter

The air filter (#18280) should be changed every 12 months. This may be more frequent for high tool usage or dirty environments.

To change filter:

1. Switch off air supply to tool.
2. Remove inlet air hose.
3. Remove filter from inside tool air inlet.
4. Fit new filter.
5. Refit inlet air hose.

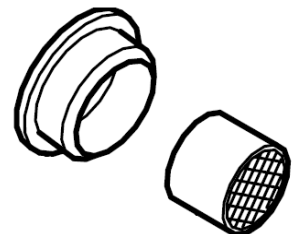

FIGURE 12 – Air filter

TIP: To help removal use a small screwdriver or a pair of internal circlip pliers.

Drive Square

To avoid internal damage (especially due to torque overload), the output drive square has been designed to shear first. This saves major internal damage and allows easy square removal.

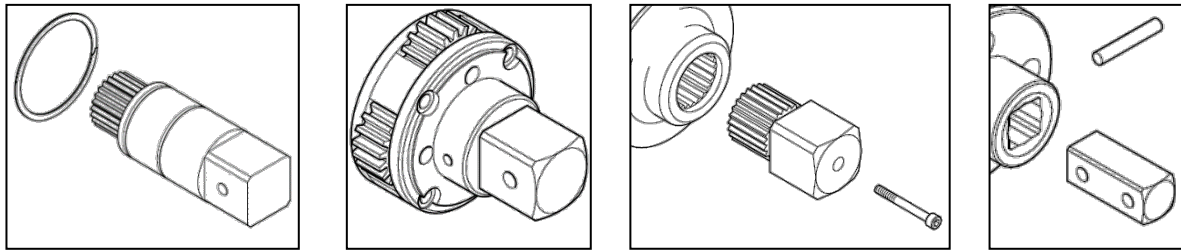

FIGURE 13 – Drive square fixing (left to right): Pin, Carrier Assembly, Screw and circlip.

Tool	Square Size	Drive Square Part Number	Fixing	Screw Torque (N-m)
PT 1 / PT 2	¾"	# 16424	Pin (# 26228)	-
PT 1 / PT 2	1"	# 16425	Pin (# 26228)	-
PT 5	1"	# 16549	Pin (#26242)	-
PT 6	1½"	# 16548	Carrier assembly.	-
PT 7	1½"	# 16295	M5 screw (# 25352.45)	8 – 9
PT 9	1½"	# 16611	M5 screw (# 25352.40)	8 – 9
PT 11	2½"	# 16323	M6 screw (# 25353.60)	16 – 18
PT 12	2½"	# 16310	M6 screw (# 25353.60) + Circlip (# 26432)	16 – 18
PT 13	2½"	# 16310	M6 screw (# 25353.60) + Circlip (# 26432)	16 – 18
PT 14	3½"	# 16309	M6 screw (# 25353.60)	16 – 18
PT 15	-	-	Application specific	-
PT 16	-	-	Application specific	-
PT 17	-	-	Application specific	-
PT 18	-	-	Application specific	-

NOTE: The drive squares are designed to be replaced by a competent service engineer with standard tools. A new fixing screw is recommended on reassembly.

TIP: If the square has sheared it may be necessary to use pliers to remove the broken parts.

Cleaning

Keep the tool in a clean condition to aid safety. Do not use abrasives or solvent-based cleaners.

Disposal

Recycling considerations:

Component	Material
Sleeve	Aluminium casting with epoxy finish.
Annulus	Alloy steel with nickel plate finish.
Reaction plate	Alloy steel with chemical black finish

SPECIFICATIONS

General

Repeatability:	+/- 5% for a given joint.
Air Supply:	Maximum pressure 6.0 bar (For maximum torque capacity). Air consumption 19 litres / sec (40 ft ³ /m [CFM]).
Recommended Lubrication:	Fuchs Silkair VG22 or Shell Tellus S2 VX15 for the Lubro Control Unit.
Temperature Range:	0°C to +50°C (operating). -20°C to +60°C (storage).
Maximum Operating Humidity:	85% Relative Humidity at 30°C.
Maximum Vibration at Handle:	< 2.5 m/s ² measured in accordance with ISO 28927-2.
Sound Pressure Level:	The sound pressure level is 85 dB(A) uncertainty K = 3dB, measured in accordance with BS EN ISO 11148-6
Environment:	Indoor & dry outdoor use.

Standard Series

Model	Torque		Free Speed (At maximum air pressure)		Velocity Ratio	
	Minimum	Maximum	Single Speed	XMTS / XAUT	Slow Speed	Fast Speed (XMTS / AUT)
PT 1	160 N·m (120 lbf·ft)	680 N·m (500 lbf·ft)	30 rev/min	150 rev/min	162.284:1	29.752:1
PT 1A	270 N·m (200 lbf·ft)	1,200 N·m (900 lbf·ft)	15 rev/min	75 rev/min	333.332:1	61.111:1
PT 2	515 N·m (380 lbf·ft)	1,700 N·m (1,250 lbf·ft)	9 rev/min	45 rev/min	508.019:1	93.137:1
PT 5	880 N·m (650 lbf·ft)	3,400 N·m (2,500 lbf·ft)	5 rev/min	25 rev/min	885.185:1	162.284:1
PT 6	880 N·m (650 lbf·ft)	3,400 N·m (2,500 lbf·ft)	5 rev/min	25 rev/min	885.185:1	162.284:1
PT 7	1,762 N·m (1,300 lbf·ft)	6,000 N·m (4,500 lbf·ft)	2.5 rev/min	12.5 rev/min	2,032.481:1	372.622:1
PT 9	2,710 N·m (2,000 lbf·ft)	9,500 N·m (7,000 lbf·ft)	1.8 rev/min	9 rev/min	2,771.015:1	508.019:1
PT 11	4,400 N·m (3,250 lbf·ft)	20,000 N·m (14,700 lbf·ft)	1.2 rev/min	6 rev/min	4,720.989:1	865.515:1
PT 12	9,500 N·m (7,000 lbf·ft)	34,000 N·m (25,000 lbf·ft)	0.5 rev/min	2.5 rev/min	10,490.271:1	1,923.232:1
PT 13	13,550 N·m (10,000 lbf·ft)	47,000 N·m (35,000 lbf·ft)	0.3 rev/min	1.5 rev/min	14,778.748:1	2,709.437:1
PT 14	22,375 N·m (16,500 lbf·ft)	100,000 N·m (73,500 lbf·ft)	0.2 rev/min	1 rev/min	25,178.608:1	4,616.078:1
PT 15	35,000 N·m (25,825 lbf·ft)	150,000 N·m (110,500 lbf·ft)	0.1 rev/min	0.5 rev/min	47,373.29:1	8,685.18:1
PT 16	46,500 N·m (34,400 lbf·ft)	200,000 N·m (147,500 lbf·ft)	0.08 rev/min	0.4 rev/min	66,739.35:1	12,235.65:1
PT 17	58,250 N·m (42,990 lbf·ft)	250,000 N·m (184,300 lbf·ft)	0.07 rev/min	0.35 rev/min	76,828.14:1	14,085.28:1
PT 18	70,000 N·m (51,630 lbf·ft)	300,000 N·m (221,270 lbf·ft)	0.06 rev/min	0.3 rev/min	83,918.27:1	15,385.14:1

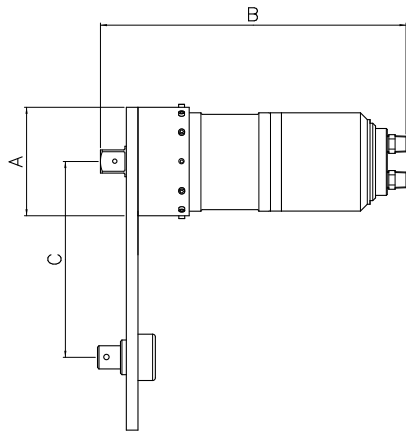

FIGURE 14 – Smaller standard series tools

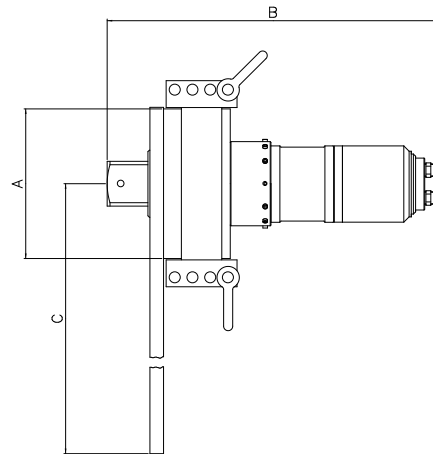

FIGURE 15 – Larger standard series tools

Model	Dimensions (mm)						Weight (kg)		
	A	B			C Minimum	C Maximum	Tool		Reaction
		Single Speed	MTS	AUT			Single Speed	XMTS / XAUT	
PT 1 (3/4")	108	292	378	361	83	217	10.6	14.1	2.2
PT 1 (1")	108	298	384	366	83	217	10.6	14.1	2.2
PT 1A	108	298	384	366	83	217	11.1	14.6	2.2
PT 2	108	298	384	366	83	217	11.1	14.6	2.2
PT 5	119	348	434	417	86	264	14.0	17.5	2.5
PT 6	119	354	440	423	86	264	14.0	17.5	2.5
PT 7	144	381	467	450	146	333	17.9	23.2	6.3
PT 9	184	376	462	445	169	351	24.4	27.9	8.3
PT 11	212	470	556	-	-	500	38.6	42.1	13.3
PT 12	248	593	679	-	Blank plate		49.8	53.3	6.5
PT 13	315	553	639	-	Blank plate		102.2	105.7	6.9
PT 14	315	650	736	-	Blank plate		119.4	122.9	10.4
PT 15	-	-	-	-	Application specific		-	-	-
PT 16	410	704	790	-	Application specific		266.5	270	-
PT 17	410	777	863	-	Application specific		281.5	285	-
PT 18	520	774	860	-	Application specific		376.5	380	-

Due to continuous improvement all specifications are subject to change without prior notice.

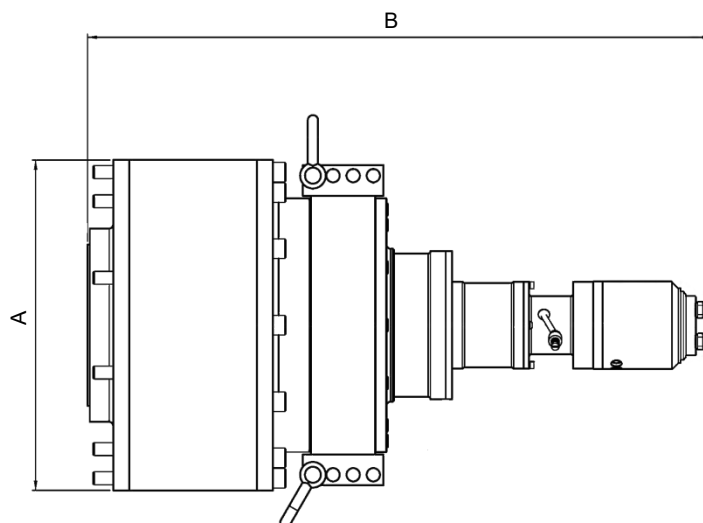

FIGURE 16 – PT 15 – 18

DECLARATION OF INCORPORATION

EU Declaration of Incorporation (No 0024V1)

The object of the declaration:

Pneutorque® Remote Control Standard Series tools.

Model Names (Part Numbers):

PT 1 (16011.X*** & 16031.X***), PT 1A (16097.X*** & 16098.X***), PT 2 (16013.X***), PT 5 (16015.X***), PT 6 (16017.X***), PT 7 (16066.X***), PT 9 (16072.X***), PT 11 (16046.X***), PT 12 (18086.X***), PT 13 (16052.X***), PT 14 (16045.X***), PT 15(18089.X***), PT 16 (18090.X***), PT 17 (18088.X***), & PT 18 (16054.X***).
Serial Number – All.

The object of the declaration described above is in conformity with the relevant union harmonisation legislation:

Directive 2006/42/EC on Machinery.

The object of the declaration described above has been designed to comply with the following standards:

EN ISO 12100:2010

The basis on which conformity is being declared:

This declaration is issued under the sole responsibility of the manufacturer. The technical documentation required to demonstrate that the products meet the requirements of the above directives has been compiled by the signatory below and is available for inspection by the relevant enforcement authorities.

The machine must not be put into service until the machine into which it is to be incorporated has been deemed to conform to the applicable directives.

The authorised representative within the European Union (EU) is:

Francesco Frezza, Snap-on Equipment S.r.l., Via Prov. Carpi 33, 42015 Correggio RE, Italy

Signed for and on behalf of Norbar Torque Tools Ltd.

Signed:



Full Name:

Trevor Mark Lester B.Eng.

Date:

25 January 2021.

Authority:

Compliance Engineer.

Place:

Norbar Torque Tools Ltd., Wildmere Road, Banbury, Oxfordshire. OX16 3JU.

UK Declaration of Incorporation (No 0024V0)

The object of the declaration:

Pneutorque® Remote Control Standard Series tools.

Model Names (Part Numbers):

PT 1 (16011.X*** & 16031.X***), PT 1A (16097.X*** & 16098.X***), PT 2 (16013.X***), PT 5 (16015.X***), PT 6 (16017.X***), PT 7 (16066.X***), PT 9 (16072.X***), PT 11 (16046.X***), PT 12 (18086.X***), PT 13 (16052.X***), PT 14 (16045.X***), PT 15(18089.X***), PT 16 (18090.X***), PT 17 (18088.X***), & PT 18 (16054.X***).
Serial Number – All.

The object of the declaration described above is in conformity with the relevant UK statutory requirements:

Supply of Machinery (Safety) Regulations 2008

The object of the declaration described above has been designed to comply with the following standards:

BS EN ISO 12100:2010

The basis on which conformity is being declared:

This declaration is issued under the sole responsibility of the manufacturer. The technical documentation required to demonstrate that the products meet the requirements of the above legislation has been compiled by the signatory below and is available for inspection by the relevant enforcement authorities.

The machine must not be put into service until the machine into which it is to be incorporated has been deemed to conform to the applicable regulations.

Signed for and on behalf of Norbar Torque Tools Ltd.

Signed:



Full Name:

Trevor Mark Lester B.Eng.

Date:

13 May 2021.

Authority:

Compliance Engineer.

Place:

Norbar Torque Tools Ltd., Wildmere Road, Banbury, Oxfordshire. OX16 3JU.

TROUBLE SHOOTING

The following is only a guide, for more complex faults please contact your local Norbar distributor or Norbar directly.

Problem	Likely Solutions
Tool output does not rotate when control system operated.	<ul style="list-style-type: none"> Check air supply is functioning & connected. Check air pressure setting (at least 1 bar required). Check correct setting of control system. Output drive square sheared, see maintenance section to replace. Gear train or air motor is damaged, return for repair.
Drive square sheared.	See maintenance section to replace.
Tool does not stall.	<ul style="list-style-type: none"> Tool has not achieved torque, increase air pressure. Fastener sheared or thread stripped. Gear train or air motor is damaged, return for repair.

GLOSSARY OF TERMS

Word or Term	Meaning
Air pressure graph	Graph to show air pressure setting for required torque.
BSP	British Standard Pipe, this is a thread size.
CFM	Cubic Feet per minute (ft ³ /m), a measure of air flow.
Lubro Control Unit	Unit to provide filtering and lubrication along with pressure regulation. A Lubro Control Unit is supplied with some PneuTorques.
PT	PneuTorque®; the product name.
Reaction Arm	Device to counteract applied torque.
Tool Control System	Pneumatic circuit to control operation of remote PT.
Velocity Ratio	The gearing ratio of the PT.
XAUT	Auto Two speed. X = Remote.
XMTS	Manual Two Speed. X = Remote.

NORBAR TORQUE TOOLS LTD

Wildmere Road, Banbury,
Oxfordshire, OX16 3JU

UNITED KINGDOM

Tel + 44 (0)1295 270333

Email: enquiry@norbar.com

To access latest versions
of all Norbar Operator
Manuals, scan the QR
code below.



To find your nearest
Norbar company or
authorised distributor,
scan the QR code below.



www.norbar.com