

• Ratchet

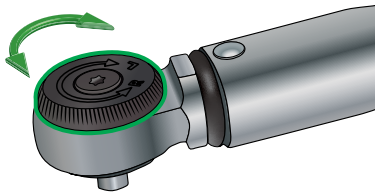

• Fixed Head

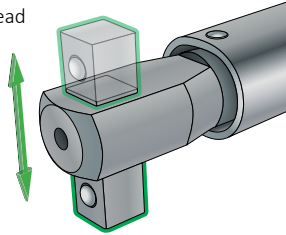

• Spigot End

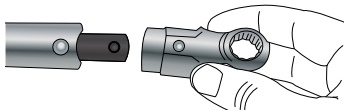

• Female Torque Handle

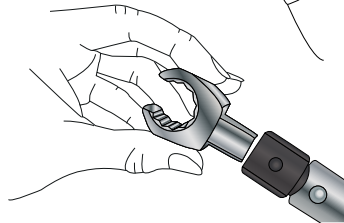

**NORBAR TORQUE TOOLS LTD**  
Wildmere Road, Banbury,  
Oxfordshire, OX16 3JU  
UNITED KINGDOM  
Tel + 44 (0)1295 270333  
Email enquiry@norbar.com



**NORBAR TORQUE TOOLS**  
45-47 Raglan Avenue, Edwardstown,  
SA 5039  
AUSTRALIA  
Tel + 61 (0)8 8292 9777  
Email enquiry@norbar.com.au



**NORBAR TORQUE TOOLS INC**  
36400 Biltmore Place, Willoughby,  
Ohio, 44094  
USA  
Tel + 1 866 667 2279  
Email inquiry@norbar.us



**NORBAR TORQUE TOOLS PTE LTD**  
194 Pandan Loop  
#07-20 Pantech Business Hub  
SINGAPORE 128383  
Tel + 65 6841 1371  
Email enquires@norbar.sg



**NORBAR TORQUE TOOLS (SHANGHAI) LTD**  
91 Building-7F, No.1122 North Qinzhou Rd,  
Xuhui District, Shanghai  
CHINA 201103  
Tel + 86 21 6145 0368  
Email sales@norbar.com.cn



**NORBAR TORQUE TOOLS INDIA PVT. LTD**  
Plot No A-168, Khairne Industrial Area,  
Thane Belapur Road, Mahape,  
Navi Mumbai – 400 709  
INDIA  
Tel + 91 22 2778 8480  
Email enquiry@norbar.in



View our 'How to Use a Torque Wrench'  
Video at:

[www.norbar.com/HowtoUseATorqueWrench](http://www.norbar.com/HowtoUseATorqueWrench)



## Slimline™ 'P' Type Torque Wrenches



**1**

- Unlock
- Déverrouiller la mollette
- Entsichern
- Sbloccare
- Desbloquear

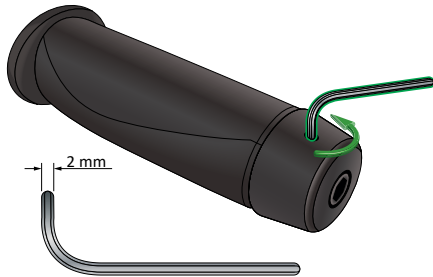
**2**

- Adjust
- Régler
- Einstellen
- Regolare
- Ajustar

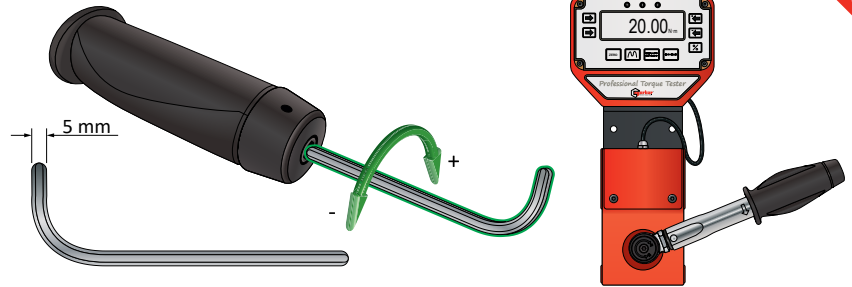
**4**

- Pull smoothly on the handle in direction indicated by arrow on body tube
- Tirer doucement sur la poignée dans le sens de la flèche sur le tube.
- Drücken Sie langsam auf den Handgriff in die Richtung, welche durch den Pfeil auf dem Rohr angezeigt wird.
- Tirare lentamente sulla manopola nella direzione indicata dalla freccia sul corpo del tubo.
- Tire suavemente del mango en la dirección de la flecha que esta marcada en el tubo

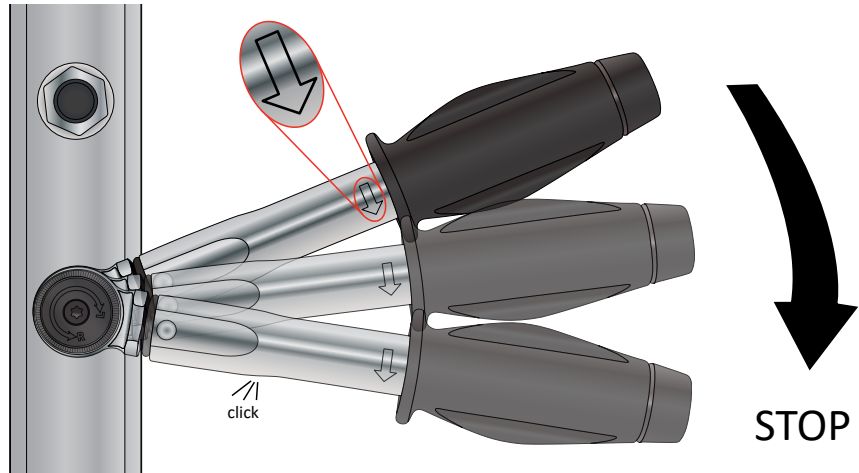
**3**

- Lock
- Verrouiller la molette
- Sichern
- Bloccare
- Bloquear

